



McFarlane Aviation Products

Instructions for Continued Airworthiness

McFarlane Aviation Inc. FAA-PMA Part Number MC0442512-1 Shimmy Dampener Assembly
 FAA PMA Number: PQ3732CE

**Notice: Verify that this document is the latest approved revision before use! Current version can be found at:
www.McFarlaneAviation.com/ICA**

Approved By:

Quality Assurance Manager

Engineering Manager

Production Manager

Revisions

Revision	Date	Summary
Original	2/14/2018	Original release
A	8/19/2019	Updated Figure 1 and minor changes to instructions as marked on pages 2-4.
B	11/4/2019	Removed Spring Insertion Tool, Added Piston Installation Tool, updated images to include revised sub-components, revised servicing instructions, various other small changes.

List of Effective Pages

Page	Rev/Date
2, 3, 4, & 5	A 8/19/2019
2, 3, 4, 5, & 6	B 8/30/2019

Instructions for Continued Airworthiness
McFarlane Aviation Inc. FAA-PMA Part Number MC0442512-1 Shimmy Dampener Assembly
FAA PMA Number: PQ3732CE

Notice: Verify that this document is the latest approved revision before use! Current version can be found at:
www.McFarlaneAviation.com/ICA

INTRODUCTION

This document is intended to provide for the continued airworthiness of McFarlane Aviation, Inc. PMA temperature compensated replacement shimmy dampener assembly eligible for installation on various Textron aircraft. The part number is MC0442512-1. For all items not related to the installation of the McFarlane Aviation, Inc. shimmy dampener assembly, refer to the basic airplane model service and parts manuals. The temperature compensation built into the MC0442512-1 Shimmy Dampener prevents leakage and vaporization of the fluid in the system as operating temperature changes.

SYSTEM DESCRIPTION

Cessna Model series 150, 152, 172, 175 and 182 aircraft feature nose gear that are typically equipped with a shimmy dampener. The shimmy dampener offers resistance to shimmy by forcing hydraulic fluid through small orifices in a piston. The dampener piston shaft is secured to a stationary part and the housing is secured to the nose wheel steering collar which moves as the nose wheel is turned right or left, causing relative motion between the dampener shaft and housing.

The P/N MC0442512-1 Shimmy Dampener Assembly is a replacement part to be used to replace Cessna P/N 0442512-1 and 0542119-1 Shimmy Dampener when the dampener needs replacement.

The P/N MC0442512-1 Shimmy Dampener Assembly for which this ICA is applicable is eligible for use on Cessna 150, A150, F150, FA150, FRA150, 152, A152, F152, FA152, 172, F172, FP172, FR172, P172, R172, 175, and 182 series aircraft that utilize the Cessna PN 0442512-1 or PN 0542119-1 Shimmy Dampener. All eligible aircraft have a total of one (1) Shimmy Dampener per aircraft.

SPECIAL OPERATING INFORMATION

The control and operation of the nose gear does not change with the installation of the McFarlane Aviation, Inc. Shimmy Dampener Assembly; see applicable Cessna/Textron Service Manual for the operational information.

PART REMOVAL, REPLACEMENT, AND SERVICE INFORMATION

Remove the old Cessna P/N 0442512-1 or 0542119-1 Shimmy Dampener and install the McFarlane replacement Shimmy Dampener Assembly P/N MC0442512-1 per the applicable Cessna/Textron Model Service Manual.

Refer to the applicable Cessna/Textron Model Service Manual for removal/installation instructions and the applicable Cessna/Textron Model Parts Manual for the hardware part numbers. NOTE: McFarlane Aviation, Inc. SDKT-4 Hardware Kit, Shimmy Dampener is available for purchase if the original hardware is not re-useable.

SERVICING WHILE SHIMMY DAMPENER IS ATTACHED TO AIRCRAFT

The following service information is to be utilized when checking the operation and fluid level on the McFarlane Shimmy Dampener Assembly P/N MC0442512-1 when on the aircraft.

A. SHIMMY DAMPENER – CHECKING OPERATION

- 1) The Operation of the shimmy dampener can be checked without removing the unit from the aircraft.
- 2) Remove the clevis bolt and nut which attaches the clevis end of the shaft to the aircraft.
- 3) Manually push and pull the shaft in and out of the shimmy dampener barrel. During this push and pull process, observe if the stroking is erratic or produces a noise identifying air inside the barrel.
- 4) If there is any concern that the shimmy dampener is not performing correctly (is low on fluid), refer to SHIMMY DAMPENER – CHECKING FLUID LEVEL.

B. SHIMMY DAMPENER - CHECKING FLUID LEVEL

- 1) The Fluid Level of the shimmy dampener can be checked without removing the unit from the aircraft.
- 2) Measure the piston (P/N 1525) position in the shaft (P/N 1523) (See Figure 1), by inserting a wire into the vent hole of the set screw (P/N 1526). Insert the wire until it hits the unthreaded part of the piston and note the wire location to the end of the shaft. Remove the wire and measure the end of the wire to the noted position on the wire. This length should be approximately 3.25 ± 0.25 inches at 70° F. If the ambient temperature during this checking process is significantly different, refer to chart in Figure 3 for an acceptable piston position.
- 3) If the position of the piston (P/N 1525) is at a different location in the shaft, refer to SHIMMY DAMPENER HYDRAULIC FLUID ADDITION, ONLY.

SERVICING WHILE SHIMMY DAMPENER IS NOT ATTACHED TO AIRCRAFT

The following service information is to be utilized when servicing the McFarlane Shimmy Dampener Assembly P/N MC0442512-1:

A. SHIMMY DAMPENER DISASSEMBLY AND REPAIR

If an issue has been found while servicing the shimmy dampener assembly, do the disassembly as follows (See Figure 1):

- 1) Remove the setscrew.
- 2) Remove the Filler Plug and drain the hydraulic fluid from the shimmy dampener assembly.
- 3) Remove the spring and floating piston from the shaft assembly. (See Figure 4 for Service Tool Recommendation)

Instructions for Continued Airworthiness
McFarlane Aviation Inc. FAA-PMA Part Number MC0442512-1 Shimmy Dampener Assembly
FAA PMA Number: PQ3732CE

Notice: Verify that this document is the latest approved revision before use! Current version can be found at:
www.McFarlaneAviation.com/ICA

- 4) Remove the retaining rings and head bearings from each end of the barrel.
- 5) Pull the shaft assembly from the barrel.
- 6) Remove all O-rings, Quad-rings and backup rings and replace with new components.
- 7) Examine the piston, shaft, spring, floating piston and set screw for serviceability. NOTE: Only minor scuffing of the piston OD is acceptable.
- 8) Examine both head bearings for wear on the ID. The bore diameter should not exceed 0.508". Examine all seal contact surfaces for scratches or other injurious defects.
- 9) Examine the piston to shaft attachment (spring pin).
- 10) Examine the inside surface of the barrel. The barrel should not have any deep scratches or gouges. Minor discoloration or small scratches are acceptable.
- 11) Examine the retainer rings for lack of tension, distortion, or other defects.
- 12) Clean all parts in a petroleum solvent or mild water/detergent solution. All parts must be rinsed, clean and dry.
- 13) Replace all O-rings, Quad-rings and backup rings, filler plug and any other worn or damaged parts (Note: Replacement parts including the Seal Kit P/N SDKT-7 are available thru McFarlane Customer Service)

B. SHIMMY DAMPENER ASSEMBLY (Refer to Figure 1)

- 1) Before you assemble the shimmy dampener, make sure there are no sharp edges on the parts that can result in damage of the O-rings or packing ring when assembled. Put lubricant on all internal parts with MIL-PRF-5606H hydraulic fluid before assembly.

CAUTION: Dirt and dust can cut the seals in the barrel. Keep all parts clean during assembly.

- 2) Install a new O-ring on the floating piston. Then install the floating piston, spring, and setscrew in the shaft. Replace self-locking set screw P/N 1526. (Note floating piston orientation) (See Figure 4 for Service Tool Recommendation)
- 3) If removed, install the piston to the shaft with the spring pin (Note: ensure that all holes in the piston line up with those on the shaft). The shaft or piston must be supported during pin installation with plastic or wood.
- 4) Install new O-rings and backup rings in the head bearings. (ID & OD)
- 5) Install the head bearing assembly without filler hole in the end of the barrel on the clevis end of the barrel.
- 6) Install a new quad ring on the shaft piston and install the shaft assembly in the barrel using McFarlane Piston Installation Tool (PN 7394).
- 7) Install the head bearing assembly with filler hole in the open end of the barrel. (use a tube or other shop aid to assist in pressing bearing)
- 8) Install the retaining rings which retain the head bearings in both ends of the barrel using a snap ring installation tool ensuring that the snap ring is fully seated.
- 9) Service the shimmy dampener. (Refer to Shimmy Dampener Servicing below)
- 10) Install the shimmy dampener on the nose landing gear. (Refer to applicable Cessna/Textron Model Service Manual)

C. SHIMMY DAMPENER HYDRAULIC FLUID ADDITION, ONLY

- 1) Do the servicing of the shimmy dampener as follows (Refer to Figure 1):
- 2) Remove the shimmy dampener from the airplane. (Refer to applicable Cessna/Textron Model Service Manual)
- 3) Position the shimmy dampener so the barrel is vertical with the Fill Plug on the top of the assembly.
- 4) Position the shaft assembly all the way down to the non-fill hole head bearing end (P/N 1521).
- 5) Remove the set screw (P/N 1526) and spring (P/N 1527).
- 6) Slightly loosen the Filler Plug so it can leak.
- 7) SLOWLY push or pull the temperature compensating piston to the 3.25" (or other dimension per Figure 3 charts) from the end of the shaft using the piston extraction tool. (See Figure 2) This must be done very slowly, as oil must pass through the small temperature compensating orifice.
- 8) Remove the piston extraction tool.
- 9) Remove the Filler Plug.
- 10) Fill the chamber of the barrel thru the Filler Plug opening with MIL-PRF-5606H fluid using a syringe and needle or equivalent. Assure that all air is out of the barrel reservoir. Let dampener sit vertically for a period of time with the filler plug open to allow air bubbles to release. Overfill, if necessary, to assist in purging air out of reservoir. (Note: A small amount of air in the shimmy dampener is acceptable)
- 11) Install and tighten the Filler Plug.
- 12) Insert the spring and set screw into the end of the shaft assembly using a 3/16" Hex Key Driver. (Note: The set screw is positioned flush with the end of the shaft.)
- 13) Operate the completed unit by hand at the full stroke of travel to check for air. Air will make a noise as the shaft travels in and out.
- 14) Check for proper "feel" while cycling. The dampener should have freedom of travel at slow cycling speeds and substantial resistance at fast cycling speeds.
- 15) If air is trapped in the shimmy dampener assembly, repeat SHIMMY DAMPENER HYDRAULIC FLUID ADDITION, ONLY Steps 3 thru 14 ABOVE. (Note: A small amount of air in the shimmy dampener is acceptable)
- 16) Clean the dampener in cleaning agent.
- 17) Dry the dampener with a clean cloth.
- 18) Install the shimmy dampener on the airplane. (Refer to applicable Cessna/Textron Model Service Manual)

D. SHIMMY DAMPENER SERVICING (Replacing the Hydraulic Oil)

- 1) Service of the shimmy dampener as follows (Refer to Figure 1):
- 2) Remove the shimmy dampener from the airplane. (Refer to applicable Cessna/Textron Model Service Manual)
- 3) Remove the set screw (P/N 1526) and spring (P/N 1527) using a 3/16" Hex Key Driver.

Instructions for Continued Airworthiness
McFarlane Aviation Inc. FAA-PMA Part Number MC0442512-1 Shimmy Dampener Assembly
FAA PMA Number: PQ3732CE

Notice: Verify that this document is the latest approved revision before use! Current version can be found at:
www.McFarlaneAviation.com/ICA

- 4) Remove the Filler Plug and drain the hydraulic fluid from the shimmy dampener assembly.
- 5) With the barrel vertical and the Filler Plug on top side of the assembly, position the shaft assembly all the way to the non-fill hole head bearing end (P/N 1521). Shaft will be all the way down.
- 6) Fill the chamber of the barrel thru the Filler Plug opening with MIL-PRF-5606H fluid using a syringe and needle or equivalent.
- 7) Fill the chamber inside the shaft with MIL-PRF-5606H fluid using the same equipment used in step 6, allow approximately five minutes for the air to work its way out of the system.
- 8) Install the floating piston in the end of the shaft assembly, just enough to engage the O-ring in the smooth bore. (Do not install the spring at this step yet)
- 9) Install the Filler Plug.
- 10) Cycle the shaft assembly 5 or 6 times at the full stroke of travel to remove any air trapped in the piston **groove**.
- 11) Position the shaft assembly all the way down to the non-fill hole head bearing end.
- 12) Remove Fill Plug and add fluid as necessary to bring fluid level up to the top of the filler opening. Pause for approximately five minutes for the air to work its way out of the system.
- 13) Reinstall the Fill Plug so it is not fully tightened to let fluid out.
- 14) Push the floating piston in to the 3.25" dimension (or other dimension per Figure 3 charts) from the end of the shaft using the piston extraction tool. (See Figure 2) Fluid and any remaining air should be escaping from the Fill Plug that was left untightened.
- 15) Tighten the Fill Plug.
- 16) Remove the piston extraction tool.
- 17) Insert the spring and set screw into the end of the shaft assembly. (Note: The set screw is positioned flush with the end of the shaft.)
- 18) Operate the completed unit by hand at the full stroke of travel to check for air. Air will make a noise as the shaft travels in and out.
- 19) Check for proper "feel" while cycling. The dampener should have freedom of travel at slow cycling speeds and substantial resistance at fast cycling speeds.
- 20) If air is trapped in the shimmy dampener assembly, remove the floating piston and repeat steps 6 thru 20 to remove air from the shimmy dampener. (Note: A small amount of air in the shimmy dampener is acceptable)
- 21) Clean the dampener in cleaning agent.
- 22) Dry the dampener with a clean cloth.
- 23) Insert a small wire into the set screw vent hole and measure the floating piston depth location. Verify the correct piston location per Figure 3 charts.
- 24) Install the shimmy dampener on the airplane. (Refer to applicable Cessna/Textron Model Service Manual)

NOTE: PRE-FLIGHT CHECK LIST AND 100 HOUR AIRCRAFT INSPECTION ARE NOT ALTERED AS A RESULT OF THIS INSTALLATION.

TROUBLESHOOTING

Refer to the applicable Cessna/Textron Model Service Manual for troubleshooting instructions and the applicable Cessna/Textron Illustrated Parts Catalog for component part numbers. See listing in Data Section below. Installation of the McFarlane Aviation, Inc. Shimmy Dampener Assembly does not alter the existing troubleshooting information.

PLACARDS

None applicable

DATA

All information to support the continued airworthiness of this replacement part is as defined herein and contained in:

-) Relevant Cessna/Textron Model Service Manuals.
-) Relevant Cessna/Textron Model Illustrated Parts Catalog.

INSPECTION

Installation of the McFarlane Aviation, Inc. P/N MC0442512-1 Shimmy Dampener Assembly does not alter the existing inspection requirements.

RECOMMENDED OVERHAUL PERIODS

No additional overhaul time limitations exist with the use of these parts.

p

AIRWORTHINESS LIMITATIONS

The Airworthiness Limitations section is FAA approved and specifies maintenance required under Sec. 43.16 and 91.403 of the Federal Aviation Regulations unless an alternative program has been FAA approved. No additional airworthiness limitations exist.

Instructions for Continued Airworthiness
McFarlane Aviation Inc. FAA-PMA Part Number MC0442512-1 Shimmy Dampener Assembly
FAA PMA Number: PQ3732CE

Notice: Verify that this document is the latest approved revision before use! Current version can be found at:
www.McFarlaneAviation.com/ICA

ASSISTANCE & REVISIONS

ICA revisions shall be made available on the McFarlane website, www.mcfarlaneaviation.com/ICA. For questions or assistance regarding these Instructions for Continued Airworthiness (ICA), contact McFarlane Aviation, Inc via email or phone. Email: engineering@mcfarlaneaviation.com
 Phone: 1-800-544-8594 (within the US) or 1-785-594-2741.

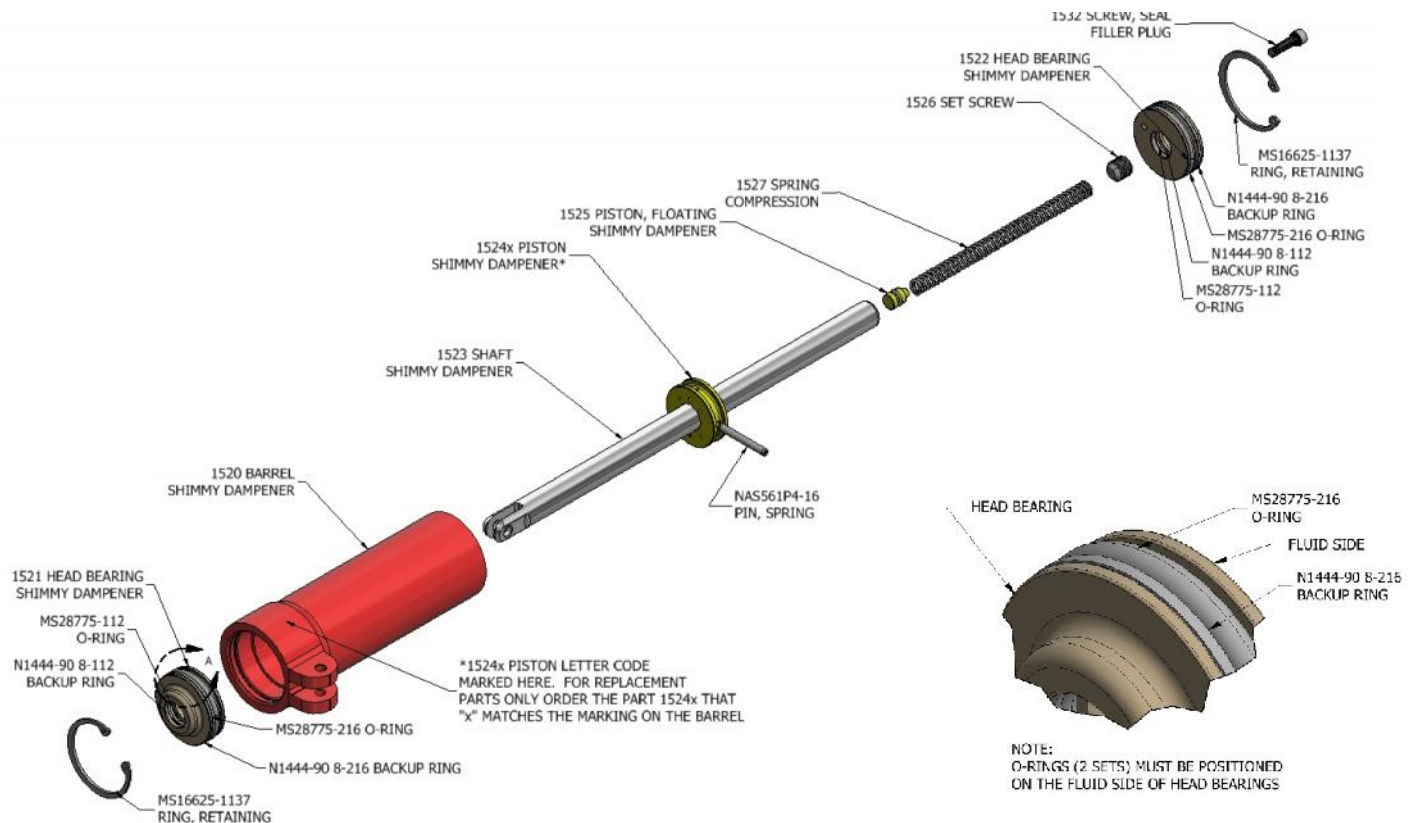

FIGURE 1 – Exploded View of McFarlane Aviation, Inc. P/N MC0442512-1 Shimmy Dampener Assembly

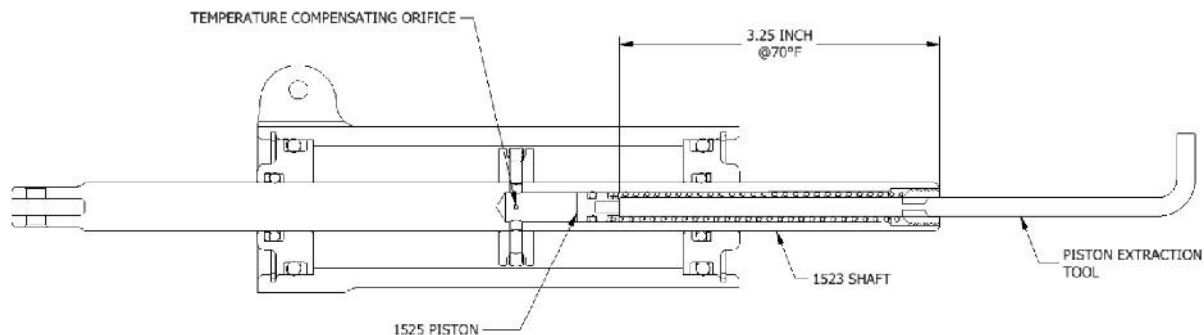

FIGURE 2 – FLOATING PISTON LOCATION

AMBIENT TEMPERATURE	PISTON POSITION FROM SHAFT END
40°F	3.88 INCHES
70°F	3.25 INCHES
100°F	2.62 INCHES

FIGURE 3 – PISTON POSITION VERSUS TEMPERATURE CHART

Instructions for Continued Airworthiness
McFarlane Aviation Inc. FAA-PMA Part Number MC0442512-1 Shimmy Dampener Assembly
FAA PMA Number: PQ3732CE

Notice: Verify that this document is the latest approved revision before use! Current version can be found at:
www.McFarlaneAviation.com/ICA

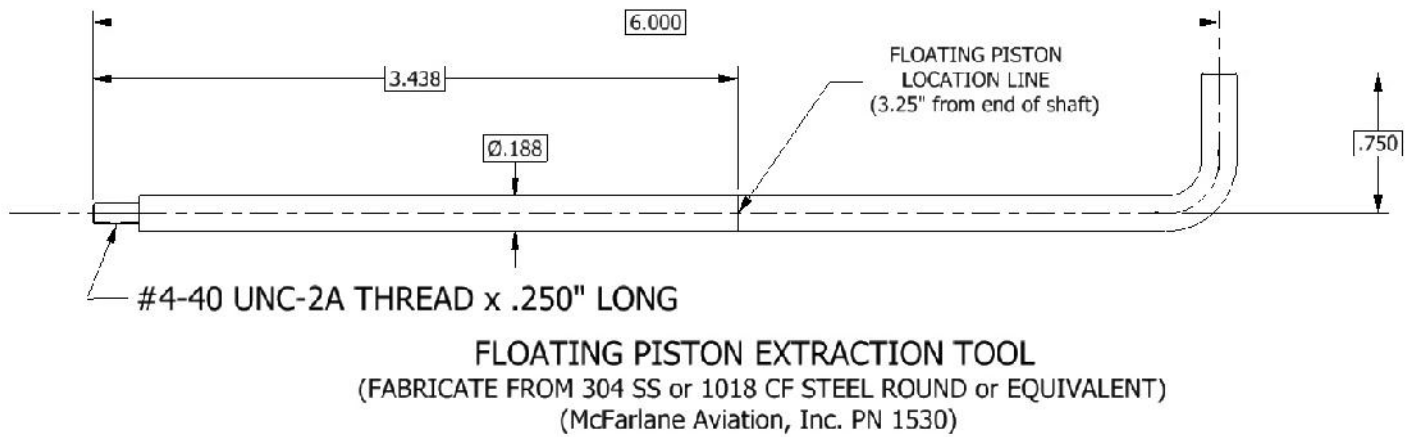

FIGURE 4 – SHIMMY DAMPENER SERVICE TOOL

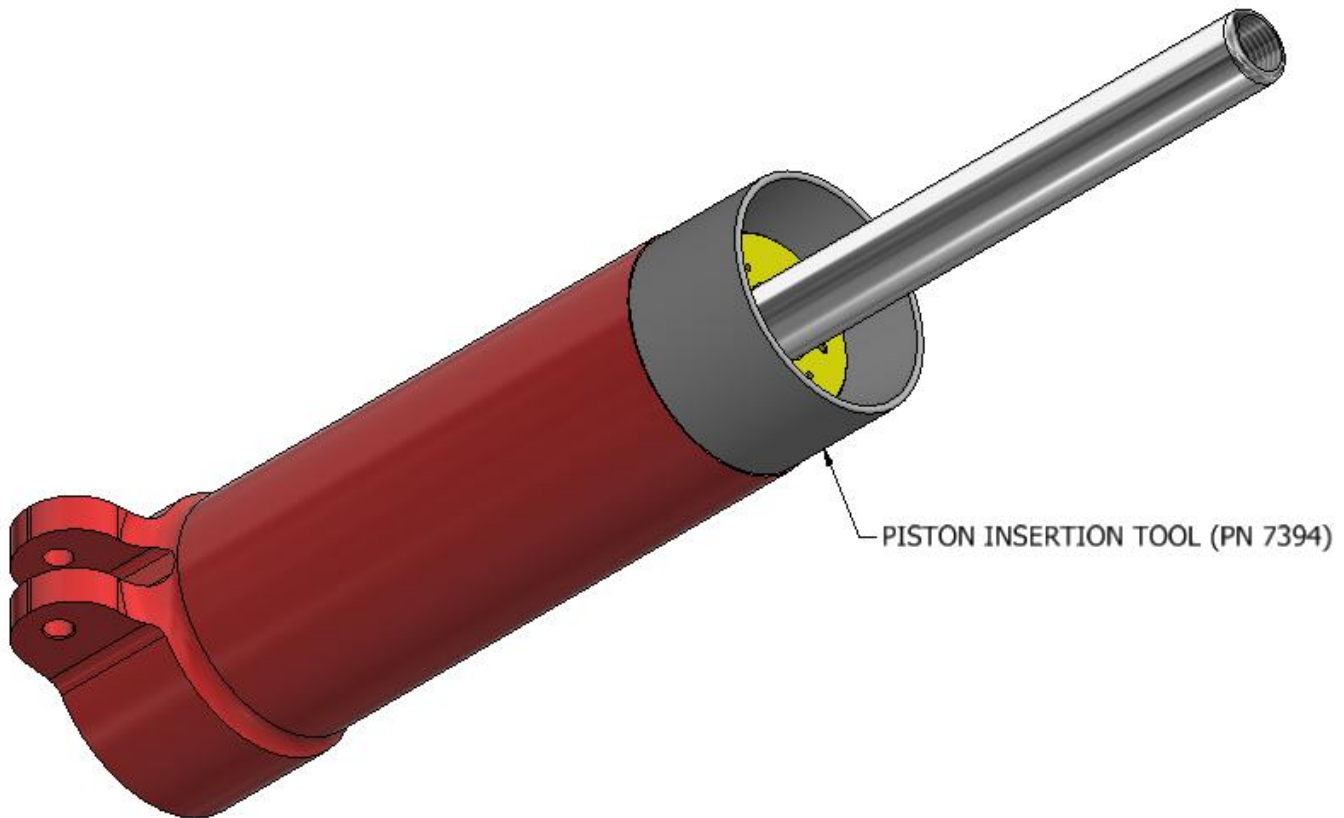

FIGURE 5 – SHIMMY DAMPENER PISTON INSTALLATION TOOL (PN 7394)