

CF3000A EMS&EFIS

User Guide



THIS UNIT HAS NOT BEEN APPROVED FOR TYPE CERTIFIED AIRCRAFT.

SUZHOU CHANGFENG INSTRUMENTS CO., LTD.

August 2020

V1.2

Copyright

CF3000A User Guide, V1.2, August 2020

© Suzhou ChangFeng Instruments Co., Ltd. All rights reserved. No part of this manual may be reproduced, copied, transmitted, disseminated or stored in any storage medium, for any purpose without the express written permission of Suzhou ChangFeng Instruments ('CFI'). CFI hereby grants permission to download this manual and of any revision to this manual onto a hard drive or other electronic storage medium to be viewed for personal use, provided that such electronic or printed copy of this manual or revision must contain the complete text of this copyright notice and provided further that any unauthorized commercial distribution of this manual or any revision hereto is strictly prohibited.

Information in this document is subject to change without notice. CFI reserves the right to change or improve its products and to make changes in the content without obligation to notify any person or organization of such changes. Visit the CFI website (www.szcfi.com) for current updates and supplemental information concerning the use and operation of this and other CFI products.

Contact Information

SUZHOU CHANGFENG INSTRUMENTS CO.,LTD.

NO.33 Heshun Road, SIP, SuZhou City, Jiangsu Prov, CHINA 215122

Phone: 0086-0512-67246502, 0086-0512-67261491

Fax: 0086-0512-67261491

Email: sz_cfi@163.com

Registering Your CF3000A

Please send an email to sz_cfi@163.com to register your CF3000A. Registering your product with CFI ensures that your contact information is up-to-date. This helps verify product ownership, can expedite warranty claims, and allows us to notify you in the event a service bulletin is published for your product. You can also optionally sign up to receive other CFI news and product announcements. CFI will not share your contact information with third parties or send you announcements without your explicit consent.

Please provide the following information when registering:

- Product model;
- Product serial number;
- Purchase date;
- Purchase location or store or distributor;
- Do you accept our service announcement for the CF3000A;
- Do you accept our CFI news and announcement for other products.

Limited Warranty

CFI warrants this product to be free from defects in materials or workmanship for one (1) year from date of shipment. CFI will, at its sole option, repair or replace any components that fail in normal use. Such repairs or replacement will be made at no charge to the customer for parts or labor. The customer is, however, responsible for any transportation cost. This warranty does not cover failures due to abuse, misuse, accident, improper installation or unauthorized alteration or repairs.

THE WARRANTIES AND REMEDIES CONTAINED HEREIN ARE EXCLUSIVE, AND IN LIEU OF ALL OTHER WARRANTIES EXPRESSED OR IMPLIED, INCLUDING ANY LIABILITY ARISING UNDER WARRANTY OF MERCHANTABILITY OR FITNESS FOR A PARTICULAR PURPOSE, STATUTORY OR OTHERWISE.

IN NO EVENT SHALL CFI BE LIABLE FOR ANY INCIDENTAL, SPECIAL, INDIRECT OR CONSEQUENTIAL DAMAGES, WHETHER RESULTING FROM THE USE, MISUSE OR INABILITY TO USE THIS PRODUCT OR FROM DEFECTS IN THE PRODUCT.

CFI retains the exclusive right to repair or replace the instrument or firmware or offer a full refund of the purchase price at its sole discretion. SUCH REMEDY SHALL BE YOUR SOLE AND EXCLUSIVE REMEDY FOR ANY BREACH OF WARRANTY.

CFI' products incorporate a variety of precise, calibrated electronics. Except for external accessories, this device does not contain any field/user-serviceable parts.

Units that have been found to have been taken apart may not be eligible for repair under warranty.

Table of Contents

Copyright1

Contact Information.....1

Registering Your CF3000A1

Limited Warranty1

1 General5

2 Integrated display6

 2.1 Main technical parameters 6

 2.2 Power interface..... 6

 2.3 Input and output interfaces of analog signals 6

 2.4 Communication interface 7

 2.5 Display control unit..... 7

 2.5.1 USB socket..... 8

 2.5.2 Buttons..... 8

 2.5.3 Brightness knob 9

 2.6 Pitot pressure, static pressure port..... 9

3 Display screens9

4 Content and parameter range of each screen display10

 4.1 Engine parameter screen 10

 4.2 Detailed description of each indicator on the engine parameter screen 10

 4.2.1 Engine speed indicator..... 11

 4.2.2 Rotor RPM indicator..... 11

 4.2.3 Manifold pressure indicator..... 11

 4.2.4 Trim indicator..... 12

 4.2.5 Flap indicator 12

 4.2.6 Throttle indicator 12

 4.2.7 Accumulated flight time, the flight time, current time and date..... 12

 4.2.8 Outside air temperature indicator 13

 4.2.9 Oil pressure, oil/water temp, voltage, current indicator 13

 4.2.10 RT indicator 13

 4.2.11 EGT & CHT indicator..... 13

 4.2.12 Fuel indicators..... 14

5 Flight attitude screen14

 5.1 Overview of flight altitude screen..... 14

 5.2 Detailed instructions of flight attitude screen 15

 5.2.1 Heading indicator 15

 5.2.2 Altitude indicator 15

 5.2.3 Slip/skid indicator 16

 5.2.4 Altimeter, vertical speed indicator and reference barometric..... 16

 5.2.5 Airspeed indicator 17

6	SETUP(MENU)	17
6.1	EMS SETUP.....	18
6.1.1	General setups and descriptions.....	18
6.1.2	RPM SETUP.....	19
6.1.3	ROTOR SETUP.....	19
6.1.4	EGT SETUP.....	19
6.1.5	CHT SETUP.....	20
6.1.6	FUEL SETUP.....	20
6.1.7	MAINFOLD PRESSURE SETUP.....	21
6.1.8	OIL PRESSURE SETUP.....	21
6.1.9	ANALOG SETUP.....	22
6.1.10	VOLT SETUP.....	22
6.1.11	AMPS SETUP.....	22
6.1.12	OAT/CarbT SETUP.....	23
6.1.13	RT SETUP.....	23
6.2	TRIM & FLAP & THROTTLE SETUP.....	23
6.2.1	TRIM & FLAP SETUP.....	24
6.2.2	SET THROTTLE.....	24
6.3	PFD SETUP.....	24
6.3.1	ALTITUDE SETUP.....	25
6.3.2	ASI SETUP.....	25
6.3.3	VSI SETUP.....	26
6.3.4	ATTITUDE CALIBRATION.....	26
6.4	TIME & DATA.....	26
6.5	SYSTEM SETUP.....	27
6.5.1	LOG MANAGEMENT.....	28
6.5.2	SOFTWARE UPDATE.....	28
6.5.3	RESART SYSTEM.....	29
7	Flight data record	29
7.1	Related setting.....	29
7.2	Log format.....	29
8	Troubleshooting	31
9	Screen Care	31
	Appendix 1: CF3000A display parameter list	32
	Appendix 2: Mounting hole cut out	33

1 General

CF3000A is a comprehensive display system especially designed for the Trikes, Autogyros, Helicopters and LSAs to monitor both flight and engine avionics. It can act as both an engine management system (EMS) and electronic flight instrument system (EFIS). The product design and dimensions are shown in Fig. 1 and 2.



Fig. 1 Product design

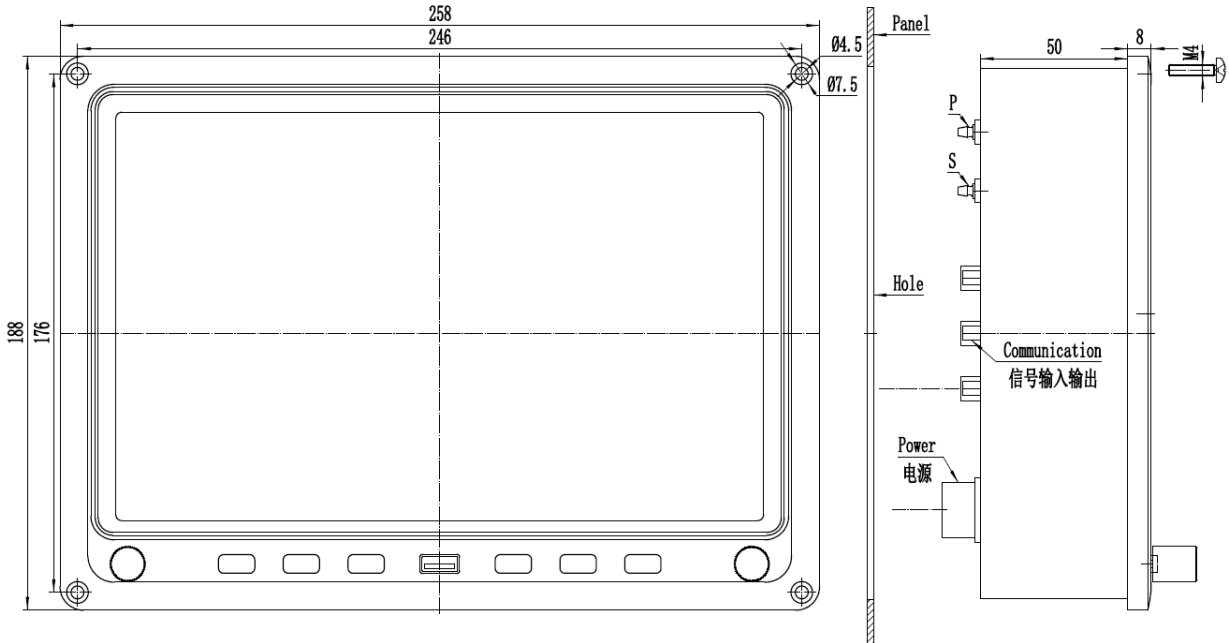

Fig. 2 Product outline and dimensions (in millimeters)

CF3000A EMS & EFIS integrated display system supports a variety of rich or simple setup combinations below

- 1) 1x integrated display + 1x parameter processor (not needed for Rotax 912/5is engine) + 1x attitude and heading reference system (AHRS)

In this setup the display can show flight parameters or engine parameters or both at the same time (see cover

illustration) in an integrated screen. Fig. 7 in section 3 shows illustrations of the displays available.

- 2) 1x integrated display + 1x parameter processor (not required for Rotax 912/5is engine or other 912 engines for a limited number of parameters)

In this setup the display can show basic flight parameters such as altitude and airspeed together with engine parameters. The second illustration in Fig. 7 of section 3 with title “Engine parameters & altimeter airspeed integrated screen” show an illustration of the display available. This configuration is more suitable for Rotorcrafts, Trikes and other aircrafts with very limited instrument panel area.

- 3) If necessary, 2x integrated displays + 1x parameter processor (not needed for Rotax 912/5is engine) + 1x AHRS can also be selected.

In this setup the two displays are interchangeable, one display shows flight parameters, the other shows engine parameters and other aircraft parameters. In case of failure of one display, the other display can switch to the integrated screen displaying both flight parameters and engine parameters at the same time (see cover illustration). Fig. 7 in section 3 shows illustrations of the displays available.

Note: at this time, the parameter processor and AHRS need to be shared by two integrated displays.

If your aircraft is equipped with a ROTAX non-is engine and when there are many parameters to show, or the engines of other manufacturers, you would need a parameter processor. CFI parameter processor is highly adaptable and compatible. In addition to Rotax engines, it is also suitable for Lycomine, Jabiru, Continental and UL power engines.

The integrated display can obtain the engine parameter data in the following three ways: 1) When it is a Rotax 912/5is engine, it is provided by the engine ECU; 2) The sensor is directly connected to the integrated display; 3) It is provided by the parameter processor. The parameters that can be displayed in three ways are shown in Appendix 1.

2 Integrated display

2.1 Main technical parameters

- Monitor size: 258 x 188 x 58.8mm;
- Monitor weight: 2kg;
- Active display area: 216.96×135.6mm²(10.1”);
- Resolution: 1280×800;
- LCD: TFT;
- Viewing angle: 85° left & right, up & down;
- Brightness: 1000 cd/m²;
- Working voltage: 8~30 VDC;
- Power: <30W;
- Storage: TF card
- Operating temperature: -20~+70°C;
- Storage temperature: -30~+80°C;
- Humidity: ≤ 40°C,85%RH Max

2.2 Power interface

Power interface is a 6 pin socket shown in Fig. 3

Pins are defined as follows:

Pin #1: Power input + Pin #6: Power input - (GND)

Input voltage is 8 ~ 30 VDC

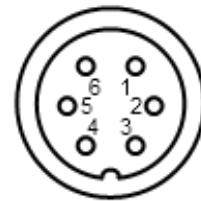

Fig. 3 Power interface

2.3 Input and output interfaces of analog signals

When it's a Rotax 912/5is engine, you don't need to buy a parameter processor. The engine parameters are communicated to the integrated display by the engine ECU through CAN. Some signals on the aircraft (such as FUEL, AMP, ROTOR TACH, ROTOR TEMP, OAT, FLAP, etc.) are directly connected to the integrated display. For other 912 engines and a limited number of parameters to be displayed, you can directly connect the signal to the integrated display. The input and output of analog signals are DB15 connectors. There are two in total. J1 male connector for receiving input from voltage signals such as FUEL. P2 female connector for receiving input from temperature (resistance) signals and also audio output. The definition of connectors is shown in the following table:

DB15 J1 Pin (Male)	Voltage signals		DB15 P2 Hole (Female)	Resistance signals	
	912/5is	Single(Direct input) display		912/5is	Single(Direct input) display
1	AMP+ (Shunt with voltage drop of 50mV)		1	OAT	
2	AMP- (Use twisted-pair shielded wire with AMP+, the shielding layer is connected to pin 15)		2	The other end of the above sensor (if any)	
3	FUEL 1		3	ROTOR TEMP	
4	FUEL 2		4	The other end of the above sensor (if any)	
5	FUEL PRESS		5	SPARE	OIL TEMP
6	SPARE	OIL PRESS	6	The other end of the above sensor (if any)	
7	FLAP		7		EGT+
8	TRIM A	THROTTLE	8		EGT-
9	TRIM U/D	VOLT	9	SPARE	Coolant temp/CHT
10	TRIM L/R	SPARE	10	SPARE	
11		ENGINE TACH \square	12	582 TACH(Input by magneto)	
12	ROTOR TACH \square			AUDIO OUTPUT	
13	912 TACH \square		13	AUDIO OUTPUT R	
14	5VDC OUTPUT		14	AUDIO OUTPUT L	
15	5VDC GND		15	AUDIO OUTPUT GND	

The other end of each temperature sensor is connected to the aircraft ground.

The voltage signal of input integrated display shall not be greater than 5V (DC). Both the **oil pressure** and fuel pressure sensors must be voltage type sensors with an output value of 0.5 to 4.5V. It is recommended to use 5K Ω , 10K Ω or 20K Ω displacement potentiometers for flap, trim and throttle. The 5VDC output by the 14 pin can be used for sensors with a total power of no more than 1W (200mA).

2.4 Communication interface

RS232 and CAN are used for communication with the interface processing module and DB9 connectors are used. There are 3 connectors in total. The power supply for the parameter processor and AHRS is also provided through the connector. J3 male connector is used to connect the parameter processor. J4 male connector is used to connect the attitude and heading reference system. P5 female connector is used to communicate with the CAN of Rotax 912/5is engine ECU. The definition of connectors is shown in the following table:

DB9 J3 Pin (Male)	Parameter processor	DB9 J4 Pin (Male)	AHRS	DB9 P5 Hole (Female)	912/5is engine parameters
2	Rx	1	5V+	1	CANA-H
3	Tx	2	Rx	2	CANA-L
5	GND	3	Tx	3	CANB-H
7	IN+	5	GND	4	CANB-L
8	12V+	8	12V+	6	CANA-G
9	GND			9	CANB-G

2.5 Display control unit



Fig. 4 Display control unit

The control part of the display is located at the lower part of the front panel, on which there is a USB port, six buttons and two brightness knob (see Fig. 4).

2.5.1 USB socket

The USB port on the lower middle on the front panel is used to download flight data and upload software updates.

2.5.2 Buttons

There are six buttons in total which are used to switch on/off the screen and adjust parameter settings. The grey icons displayed above each button outlines the button’s function. In different screens / menus, the function of each button may be different. Here is a list of button functions:

- CYCLE:** Screen switch button. Press this button to cycle between different display screens.
- ALT SET:** Press this button to pop up the barometric and altitude setting button's function, you can set & adjust the reference barometric and the selected altitude, one-key mean sea level barometric, etc., press the SETTING button to enter Baro & Altimeter Setting interface.
- RETURN:** Return button, press this button to return to the previous menu or screen display interface.
- DATA:** Press this button to enter the data display page. The will show the data of each parameter in a list format. Continue to press the PFD button to display the flight parameter data. See Fig. 8 in section 3 for details.
- MENU:** Menu button, press it to enter the setting main menu.
- ENTER:** Select button, press it to enter the settings or the next submenu.
- UP and DOWN:** Press these two buttons to move up and down the ★ pointer in the menu, or change the value of a setting (e.g. parameter display unit, switching displays, adjusting numerical value, measurement item, language). Long press to quickly adjust. In the multi-level menu and setting interface, the two brightness knobs on the left and right also have the functions of UP and DOWN.
- CANCEL:** Cancel button, press this button to cancel the selection or setting just made.
- OK:** Confirm the current settings.

↑ and ↓ : Up and down buttons, ↑ and ↓ will appear in the interface displaying the flight attitude screen. Press these two buttons to move up and down the small aircraft mark in the screen.

Special reminder: Set the altimeter before each take-off. In airports with a control tower, set the field reference barometric according to the reference barometric value provided by the controller. In airports without a control tower, select Zero Altitude in the BARO setting menu, then the integrated display will set the field reference barometric with the current barometric it senses, and the altimeter will be set to zero.

An example of menu operation is given below:

1) Press **ALT SET** button to pop up the barometric and altimeter setting button's function, as shown in the upper picture of Figure 5. press the Baro and SALT keys to pop up the number keys, as shown in the middle picture of Figure 5, press the number keys to adjust the field barometric and the selected altitude, long press to quickly adjust. Press the MSL button to set the mean sea level barometric as the reference barometric, and the back ground color of the barometric box will turn blue 1013 mb. Press the SETTING button to enter Baro & Altimeter Setting interface.

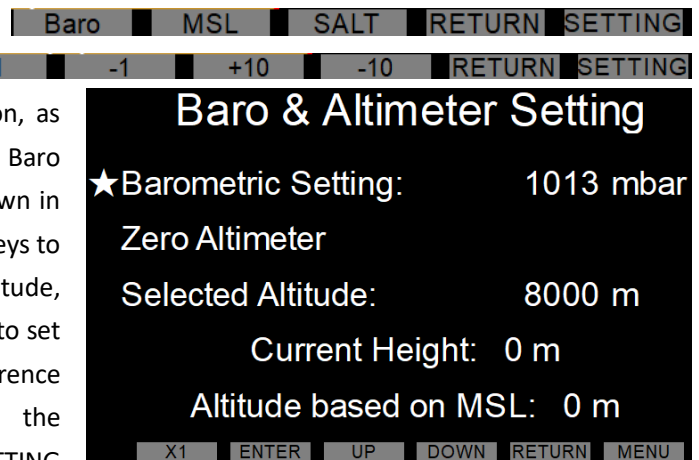

Fig. 5 Select setting item

The real-time button's function of field barometric and altimeter setting will disappear after 6 seconds of no pressing.

2) Press the UP or DOWN button, move the ★ pointer up or down to select the item to be set in the menu, as

shown in the bottom picture in Fig 5. At Baro and Altimeter Setting submenu, select Barometric Setting to set the local barometric, or select Zero Altimeter to set the current barometric sensed by the integrated display as the local barometric pressure, or select Selected Altitude to adjust the selected altitude.

- 3) Press ENTER to confirm the selection, and the set value will be displayed in red background and white character color, as shown in Fig. 6.

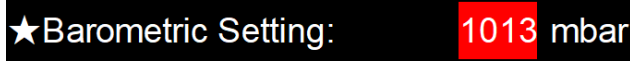

Fig. 6 Confirm setting item selection

- 4) Press the UP or DOWN button to adjust the value. After the value is adjusted to the target value, press the OK button to confirm the setting and return to the screen or exit the setting. If you want to adjust quickly, press the ×1 button to switch to ×10. This increases the adjustment speed to 10 times the original speed. Press the same button again to switch back. Only this page has the ×1 button.

2.5.3 Brightness knob

The knob in the lower right corner of the display unit adjusts the display's brightness. Clockwise/anticlockwise rotation increased/decreases brightness respectively. In the multi-level menu and setting interface, the two luminance knobs on the left and right also have the functions of UP and DOWN.

2.6 Pitot pressure, static pressure port

P and S are pneumatic ports, which are connected to pitot pressure and static pressure respectively. It is recommended to use 4*2.5 PU tube to connect.

3 Display screens

In addition to the multi-level menu interface, setting page and data page, CF3000A has four display screens, as shown in Fig.7. Press CYCLE button to cycle through the screen.



Engine parameters & flight attitude integrated screen (closed automatically when attitude module is off)

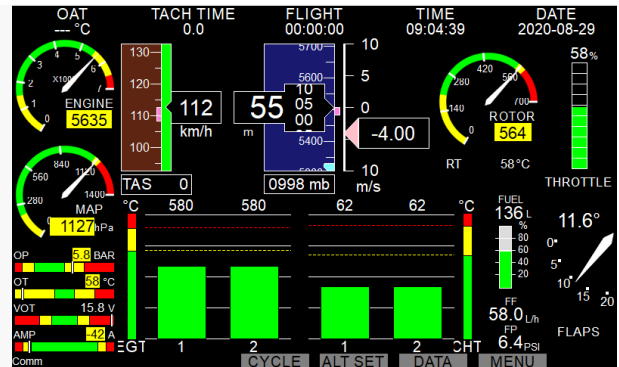

Engine parameters & altimeter airspeed integrated screen (displayed when attitude module is off)

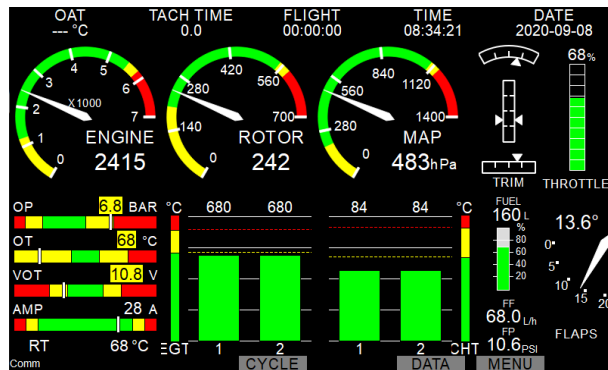

Engine parameter screen

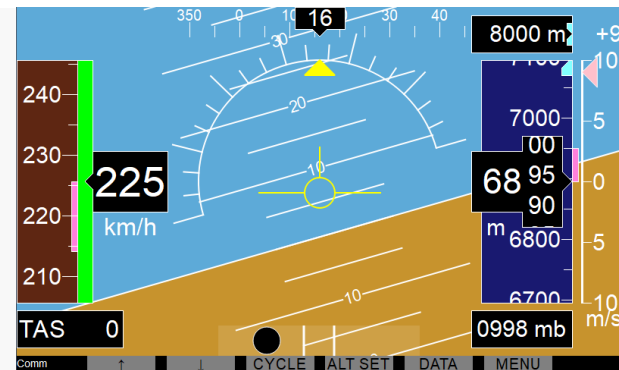

Flight attitude screen (closed automatically when attitude module is off)

Fig. 7 CF3000A display screen

The system can display all the flight parameters, engine parameters and other parameters of the aircraft in both graph and digit form, providing intuitive data visualization. In normal working range it displays text in white and graphics in green. In critical working range it displays both text and graphics in yellow. In overload working range both text and graphics are in eye-catching red with numbers flashing and the alarm sounding to warn the pilot. Working range can be preset by users.

In any of the four display screens from Fig. 7 you can press the DATA button to enter the data page. This displays the engine parameter data in the form of a list. Press the PFD button to display the flight parameter data and then press EMS to switch back the engine parameter data. Press RETURN to exit, as shown in Fig. 8.

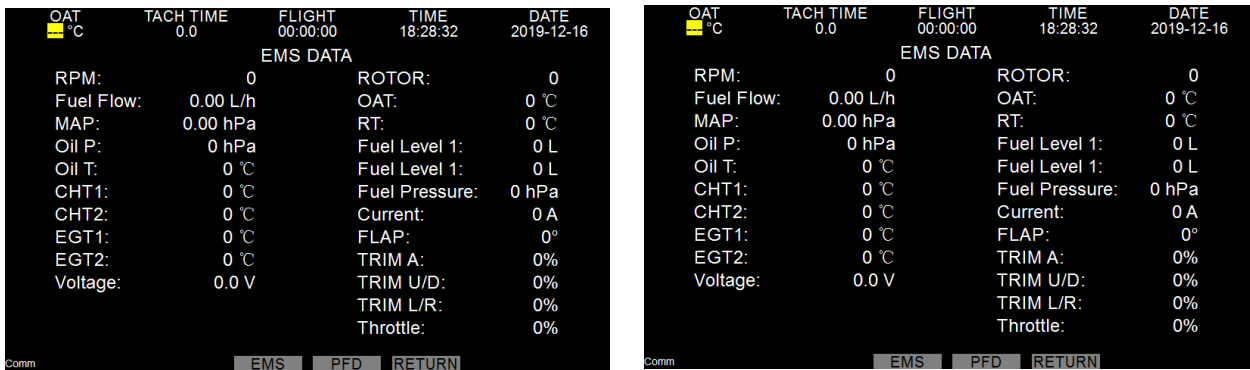

Fig. 8 Data page

4 Content and parameter range of each screen display

4.1 Engine parameter screen

The engine parameter screen in Fig. 9 is one of the main display contents of CF3000A.

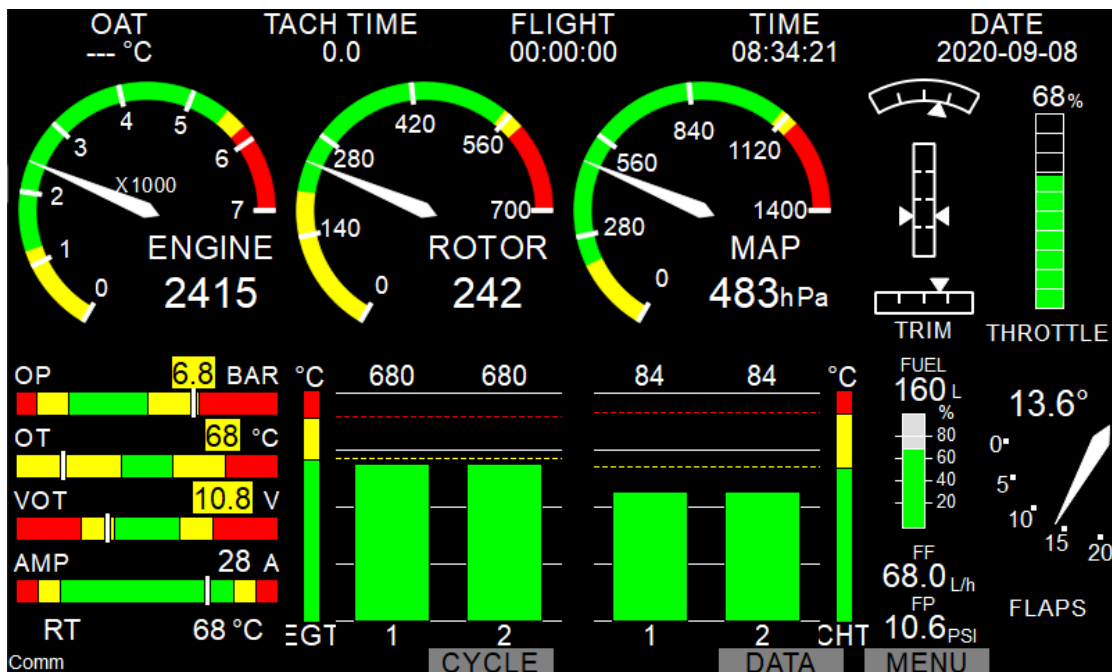

Fig. 9 The engine parameter screen

4.2 Detailed description of each indicator on the engine parameter screen

The following sections give a detailed description of each indicator.

4.2.1 Engine speed indicator



Fig. 10 Engine speed indicator

Fig. 10 shows the engine speed indicator. The engine speed indicator has a chromatic dial with a pointer and display of the value. The default range is 7000 and the default marking color band is set with Rotax engine parameters in mind. See [6.1.2 RPM SETUP](#) for setting.

4.2.2 Rotor RPM indicator

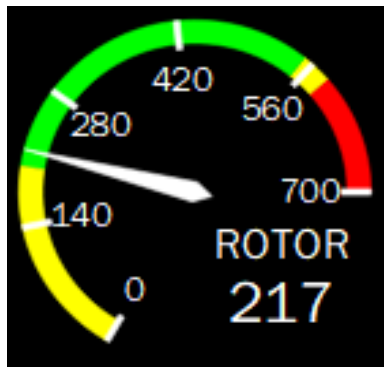

Fig. 11 Rotor RPM indicator

Fig. 11 shows the rotor RPM indicator. The rotor RPM indicator has a chromatic dial with a pointer and display of the value. This can optionally be turned off. The default range is 700 rpm, and the default number of pulses per revolution is 10. See [6.1.3 ROTOR SETUP](#) for setting.

4.2.3 Manifold pressure indicator

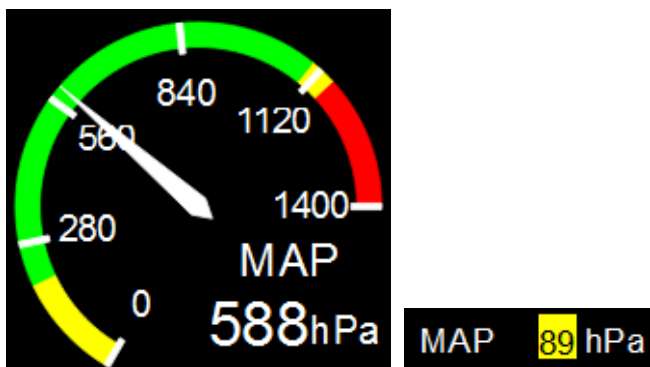

Fig. 12 Manifold pressure indicator

Fig. 12 shows the manifold pressure indicator. In the engine parameter screen, the manifold pressure indicator has a chromatic dial with a pointer and display of the value. In the engine parameter & flight attitude integrated screen and the engine parameter & altimeter airspeed integrated screen, it is just a display of the value which can be turned off. When a single display is used without a parameter processor, the manifold pressure display will turn off automatically. The unit can be hPa or inHg. See [6.1.7 MAINFOLD PRESSURE SETUP](#) for setting.

4.2.4 Trim indicator

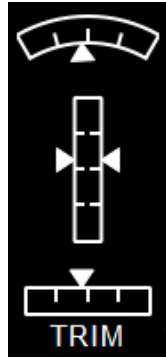

Fig. 13 Trim indicator

Fig. 13 shows the trim indicator. From top to bottom, it is the trim indicator of aileron, horizontal rudder and rudder. The trim indicator is only displayed in the engine parameter screen and can be individually optionally turned off. When only a single display is used, the trim indicator will turn off automatically. See [6.2.1 TRIM & FLAP SETUP](#) for setting.

4.2.5 Flap indicator

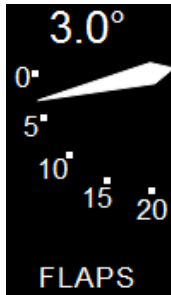

Fig. 14 Flap indicator

Fig. 14 shows the flap indicator. It indicates the flap position. The default range is 0 ° ~ 20 °. The range can be modified and the display can be turned off. See [6.2.1 TRIM & FLAP SETUP](#) for setting.

4.2.6 Throttle indicator

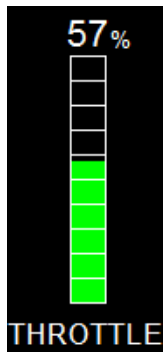

Fig. 15 Throttle indicator

Fig. 15 shows the throttle (lever) indicator, which can be turned off. See [6.2.2 SET THROTTLE](#) for setting.

4.2.7 Accumulated flight time, the flight time, current time and date



Fig. 16 Accumulated flight time, the flight time, current time and date

Fig. 16 shows three time and one date information, which are displayed in other screens and menus except for the flight attitude screen.

TACH TIME: Accumulated flight time. Records the total flight time and can be manually reset.

FLIGHT: Time of this flight. When the engine speed reaches a specified timing speed for 10 seconds, start timing until the speed is lower than the timing speed for 10 seconds, then stop timing, and keep the data. The next time the condition is met, it will automatically reset and start timing. The default timing speed is 1000 rpm, and the timing speed can be adjusted.

TIME: Current time.

DATE: Current date.

See [6.4 TIME & DATA](#) for setting.

4.2.8 Outside air temperature indicator



Fig. 17 Outside air temperature indicator

Figure 17 shows the indication of aircraft external air temperature (OAT). It will give an early warning when the temperature is less than 3°C. It will give an alarm when the temperature is less than 0°C. The display can be turned off. See [6.1.12 OAT/CarbT SETUP](#) for setting.

4.2.9 Oil pressure, oil/water temp, voltage, current indicator

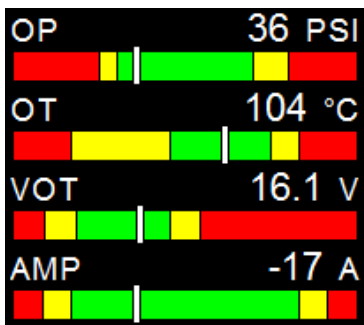

Fig. 18 Oil pressure, oil/water temp, voltage, current indicator

Fig. 18 oil pressure (OP), oil temperature (OT), voltage (VOT) and current (AMP) indicators are respectively shown from top to bottom, and they are displayed in two ways: color tag + cursor and value. The oil pressure display can be turned off, and the unit can be PSI or BAR. The temperature measurement items can be oil temp or water temp, and the unit can be °C or °F. The unit of voltage is V and the unit of current is A. Each range can be modified, and the type of oil pressure, oil / water temp sensor needs to be confirmed or set. See [6.1.8 OIL PRESSURE SETUP](#), [6.1.9 ANALOG SETUP](#), [6.1.10 VOLT SETUP](#) and [6.1.11 AMPS SETUP](#) for setting.

4.2.10 RT indicator



Fig.19 RT indicator

Fig.19 shows the rotor shaft temperature (RT) indicator, the display can be turned off, and the unit can be °C or °F. The sensor type needs to be confirmed or set. See [6.1.13 RT SETUP](#) for setting.

4.2.11 EGT & CHT indicator

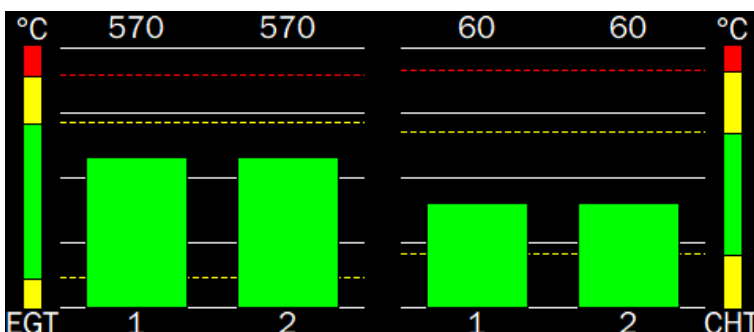

Figure 20 EGT & CHT indicator

In Fig. 20, the left EGT is the exhaust temperature indicator and the right CHT is the cylinder head temperature indicator. The unit can be ° C or ° F. For 912/5is engine EGT 4 channels can be displayed (cylinders). When using the parameter processor 2-4 cylinders can be displayed. Only 1 channel can be displayed when the signal is directly connected to the integrated display. When EGT displays more than 2 channels, the highest and lowest exhaust temperature display (the highest on the left and the lowest on the right) will be automatically selected in the engine parameter & flight attitude Integrated screen. Indication is displayed by histogram and value. When temperature column rises to the critical working area, it will turn yellow automatically. When temperature column rises to over the limit working area, it will automatically turn into red and indicate an alarm by means of digital flashing and output alarm sound. See [6.1.4 EGT SETUP](#) for setting.

The CHT changes to display one channel of coolant temperature when the engine is 912/5is. When the parameter processor is used, two to four channels of coolant temperature can be displayed. When the signal is connected directly to the integrated display, only one channel of cylinder head temperature or coolant temperature can be displayed. When the CHT display is more than two channels, the highest and lowest cylinder head temperature display (the highest on the left and the lowest on the right) will be selected automatically in the engine parameter & flight attitude Integrated screen. The indication mode is the same as the above EGT display. See [6.1.5 CHT SETUP](#) for setting.

4.2.12 Fuel indicators

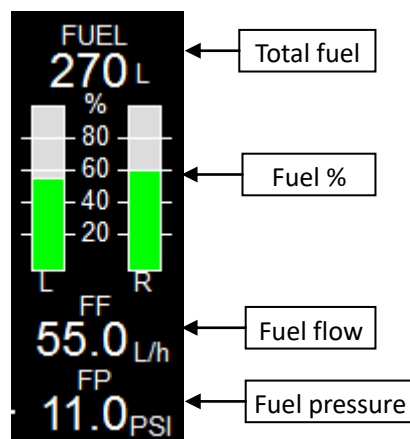

Figure 21 Fuel indicators

Figure 21 shows the fuel indicator, which indicates the fuel level, flow and fuel pressure. The upper value indicates the total fuel remaining in the two tanks. The middle green bar charts indicates the percentage of the fuel remaining in the tank. The lower value indicates the fuel flow and the lowest value indicates the fuel pressure. The fuel unit can be L or G (US system). The corresponding fuel flow is L / h or G/ h and the fuel pressure unit can be PSI or BAR. The number of oil tanks can be turned off to one or none. One is turned on by default. The fuel flow and fuel pressure display can be turned off. Many parameters can be set for these three indicators. See [6.1.6 FUEL SETUP](#) for setting.

5 Flight attitude screen

5.1 Overview of flight altitude screen

This screen contains airspeed indication, altitude indication, vertical speed indication, attitude indication, heading indication and sideslip indication, as shown in Fig.22.

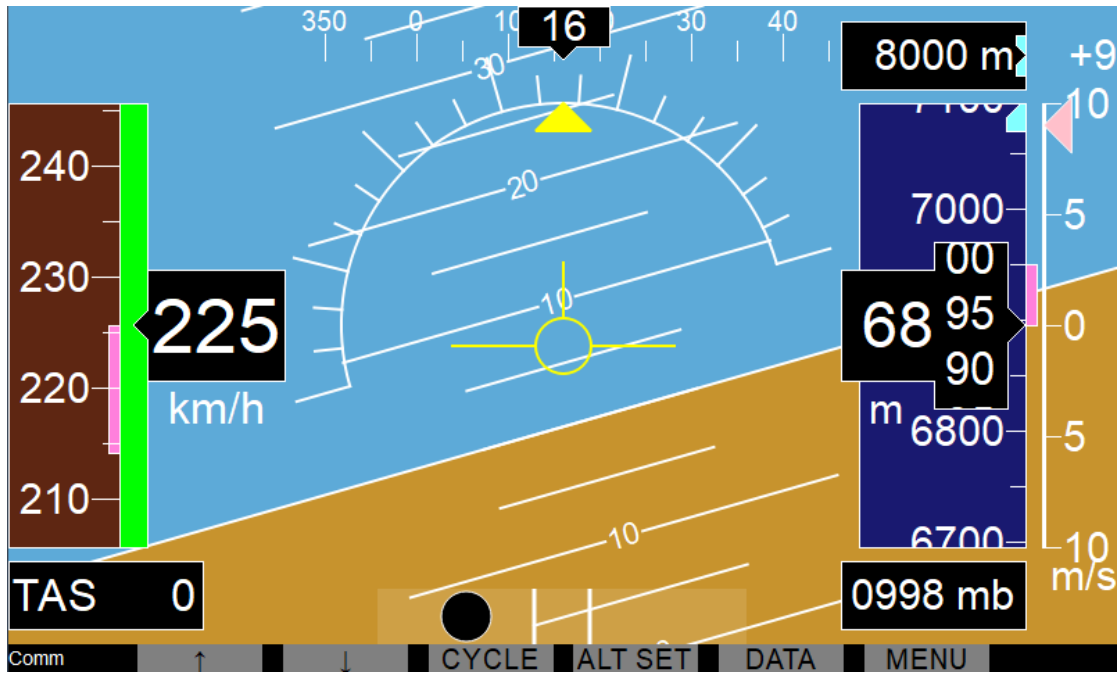

Fig. 22 Flight attitude screen

5.2 Detailed instructions of flight attitude screen

The following sections give a detailed description of each flight parameter indication.

5.2.1 Heading indicator



Fig. 23 Heading indicator

Fig. 23 shows the heading indicator. The current heading of the aircraft is indicated in the black background frame in the middle. The heading takes the magnetic North pole of the earth as 0 degree.

5.2.2 Altitude indicator

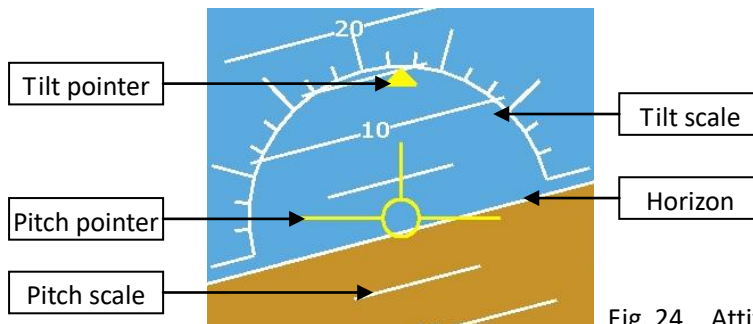

Fig. 24 Attitude indicator

Fig. 24 is an altitude indicator showing the relationship between the aircraft and the horizontal plane. The altitude indicator indicates whether the aircraft is parallel or inclined to the horizontal plane. In the picture, blue represents the sky and brown represents the ground. The pitch pointer (small yellow plane) and yellow tilt pointer are fixed. The tilt scale is 10 degrees apart, and the angle that the tilt pointer points to is the tilt angle of the aircraft. The parallel line above and below the horizon is the pitch scale line, with 5 degrees between the long and short lines. The pitch scale pointed by the pitch pointer is the pitch angle of the aircraft. When the horizon (brown ground) is above the wing of the small aircraft, it indicates that the aircraft is in a dive (descent) flight attitude. When the horizon (blue sky) is below the wing of the small aircraft, it indicates that the aircraft is in a nose-up pitch (climb) flight attitude.

5.2.3 Slip/skid indicator



Fig. 25 Slip/skid indicator

Fig. 25 shows the slip/skid indicator. The sideslip ball provides the lateral acceleration indication of the aircraft. If the black ball is in the middle of the left and right white lines, it means the aircraft is in the turning coordination state, otherwise it is in the sideslip state.

5.2.4 Altimeter, vertical speed indicator and reference barometric

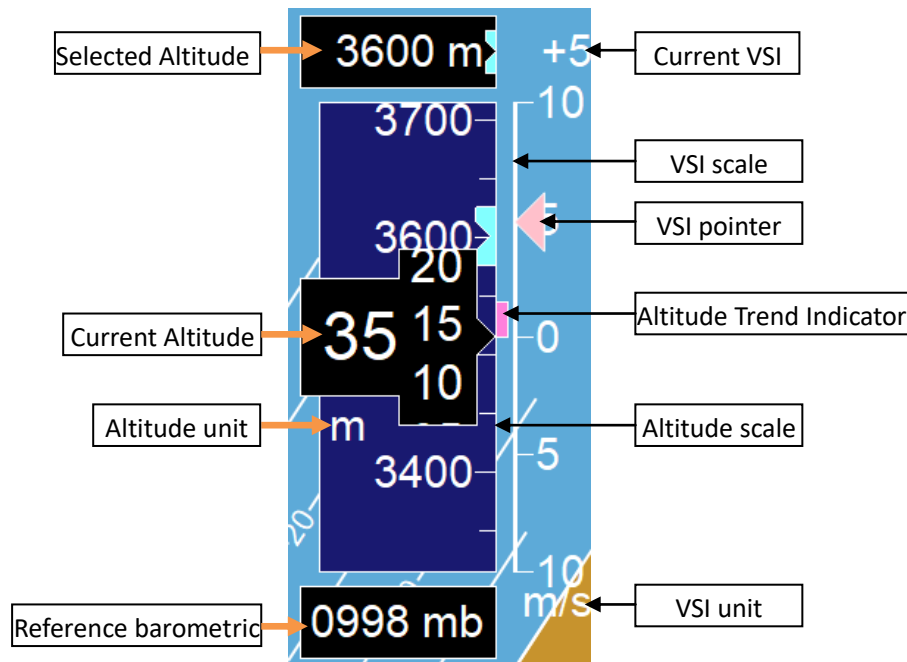

Fig. 26 Altimeter, vertical speed indicator and reference barometric

Fig. 26 shows the altimeter, vertical speed indicator, showing the reference barometric (field barometric). The altitude unit can be m or ft, the reference barometric unit can be mbar or inHg, and the vertical speed unit can be m/s or ft/min. The selected altitude is displayed above the altimeter. When the flying altitude is close to the selected altitude (± 200), the bus will move on the altimeter. When the flying altitude exceeds the selected altitude, the selected altitude box will change to Black text on yellow background. There is also a pink altitude trend indicator on the altimeter, which indicates the altitude that the aircraft will reach in 6 seconds with the current flight trend. When the reference barometric is set by the numeric keys, the background color of the reference barometric box is black, and the current altitude is the pressure altitude based on the reference barometric. When the reference barometric is the mean sea level barometric (1013.25hPa/29.92inHg) set by MSL button, This background color will change to blue 1013 mb, and the current altitude is the altitude (geometric height above the mean sea level). **Special reminder:** before each takeoff, set the altimeter to zero or set the field barometric. See [6.3.1 ALTITUDE SETUP](#) for altimeter setting and [6.3.3 VSI SETUP](#) for VSI setting.

5.2.5 Airspeed indicator

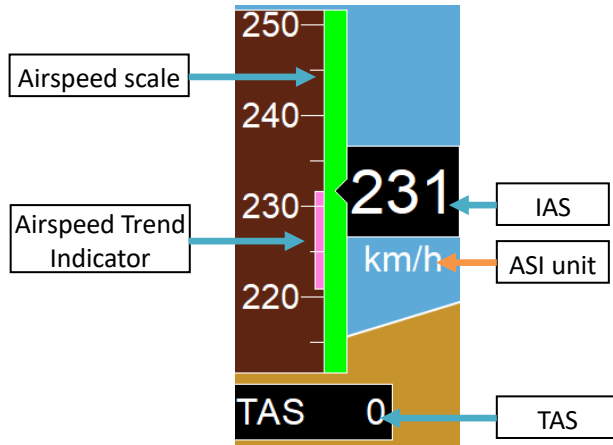

Fig. 27 Airspeed indicator

Figure 27 shows the airspeed indicator, indicating the current airspeed IAS and the authentic airspeed TAS. The unit of airspeed can be km/h or mph or knots. The airspeed marking color bands are white, green, yellow and red. The white work area is the allowable airspeed range when the flaps are down. There is also a pink airspeed trend indicator on the airspeed indicator, which indicates the airspeed that the aircraft will reach in 6 seconds with the current flight trend. See 6.3.2 ASI SETUP for setting.

6 SETUP(MENU)

Press the menu button to enter the main menu as shown in Fig. 28. In the main menu, EMS INTERFACE and LANGUAGE can be selected and setup directly. Other items be selected to enter the submenus.

There are four options for EMS interface: parameter processor, 912is / 915is, single display and auto. When auto is selected, the integrated display will automatically identify the source of engine parameter data and automatically adjust data processing and screen. The language can be Chinese (Simplified) or English.

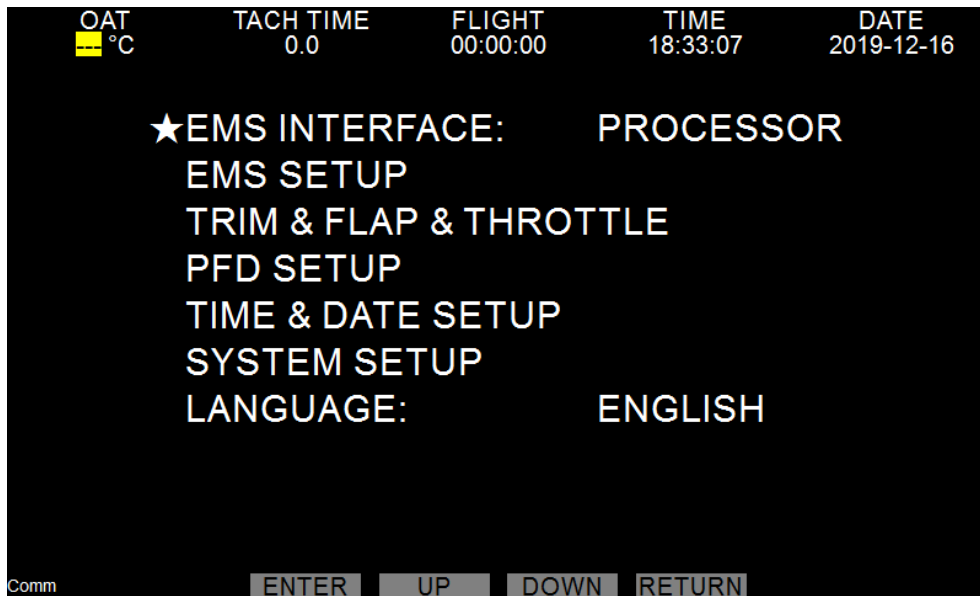

Fig.28 MENU

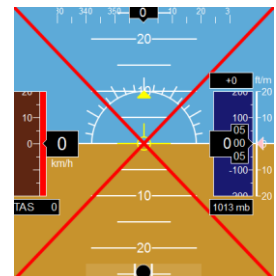

Fig. 29 AHRS not connected

Comm will appear in the lower left corner of the screen and the red light icon will flash when the parameter processor is selected for EMS interface but the parameter processor is not connected to the integrated display or the communication with the integrated display is abnormal.

LaneA will appear in the lower left corner and LaneB will appear in the lower right corner of the screen when 912/5is is selected as EMS interface. The green light will turn to the flashing red light icon when the communication of some lane CAN is abnormal.

A red ✕ will appear on the attitude display when the selected attitude indicator is ON but the module not connected to the integrated display, as shown in Fig. 29.

6.1 EMS SETUP

In the main menu, move the ★ pointer to EMS SETUP, press ENTER to enter the EMS set up submenu.

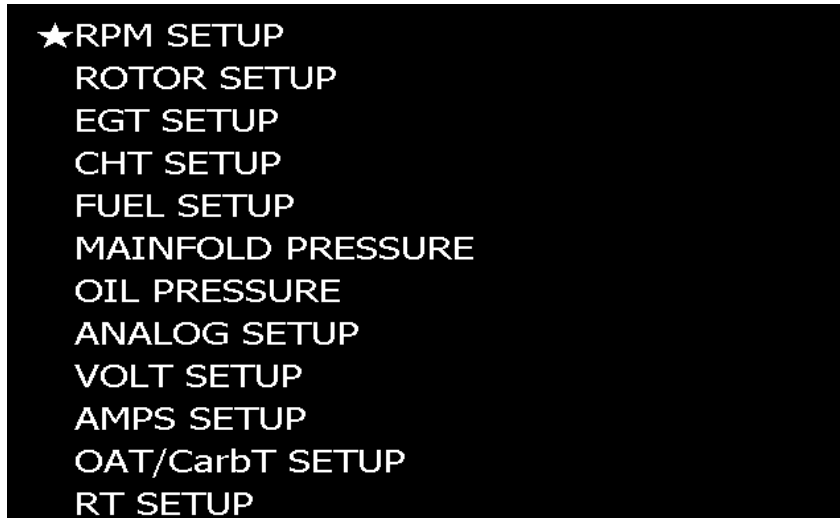

Fig. 30 EMS setup submenu

6.1.1 General setups and descriptions

There are the following items in the EMS SETUP, which are described as follows:

DISPLAY: Set up whether the display of this parameter is off (ON/OFF);

*(Parameter) **UNIT:** select the unit of this parameter; the temperature unit can be °C or °F. When switch, all relevant temperature units will be switch;

PROBE/SENSOR: Select the sensor type to collect the parameter;

DISPLAY MAX: Set up the maximum value (range) of the parameter display;

HIGH ALARM: Alarm generates when higher than this value;

HIGH CAUTION: Early warning generates when higher than this value;

LOW CAUTION: Early warning generates when lower than this value;

LOW ALARM: Alarm generates when lower than this value;

DISPLAY MIN: Set up the minimum value (starting point) of the parameter display;

ALARM: Set whether the alarm sound of this parameter is off (ON/OFF);

CALIBRATION FACTOR: The display value = measured value × (1 + correction factor) when the correction factor is a positive and negative percentage; the display value = measured value + correction factor when the correction factor is a positive and negative number. The default value of the correction factor is + 0.0% or + 0. It can be corrected by the correction factor when there is a relatively fixed error in the measured value.

The arc marking color band and the square marking color band of the integrated display are set by default according to the relevant parameters of the Rotax912 engine. **Due to this default set up may not come from the latest information, please confirm or reset according to your engine manual.**

The red color band disappears when **DISPLAY MAX/MIN** value is the same as **ALARM** value ; next, the yellow color band disappears when **DISPLAY MAX/MIN** value is the same as **CAUTION** value; The yellow color band disappears when **DISPLAY MAX/MIN** value is the same as **CAUTION** value and different from **DISPLAY MAX/MIN** value.

When the sensor is not connected or falls off and the integrated display or the parameter processor does not collect the parameter well, the value position of the parameter will display the red background and white short line and flash.



Fig. 31 Colour mark

6.1.2 RPM SETUP

In the submenu, move the ★ pointer to RPM SETUP, press ENTER to enter the RPM set up menu.

ROTATION SPEED SETUP	
★RPM DISPLAY MAX :	7000
HIGH ALARM :	6500
HIGH CAUTION :	5500
LOW CAUTION :	1500
PULSES/REV :	1
ALARM :	OFF
SENSOR :	RPM1/RPM2
CALIBRATION FACTOR :	+0.0 %

Fig. 32 RPM setup

RPM DISPLAY MAX: The default value is 7000 rpm, and the adjustment range is 8000 to 1000 with 500 rpm steps.

PULSES/REV: Per revolution of the engine correspond the number of pulses, the default value is 1, and the adjustment range is 1, 2, 3, 4, 5, 6, 1.5.

SENSOR: There is no need to select with 912/5is and a single display. The default is RPM1 / RPM2, optional RPM3 when the parameter processor is used.

If the clutter of the tach signal given by the 912engine is strong and causes the gauge to indicate abnormality, please incorporate the attached (around 500Ω)resistor between the signal input port and the ground.

6.1.3 ROTOR SETUP

In the submenu, move the ★ pointer to ROTOR SETUP, press ENTER to enter the ROTOR set up menu.

ROTOR SETUP	
DISPLAY :	ON
DISPLAY MAX :	700
HIGH ALARM :	580
HIGH CAUTION :	550
LOW CAUTION :	200
PULSES/REV :	10
★DISPLAY POSITION:	LEFT
ALARM :	OFF

Fig. 33 Rotor setup

DISPLAY MAX: The default value is 700 rpm, the adjustment range is 2000 to 500 with 50 rpm steps.

PULSES/REV: Per revolution of the rotor correspond to the number of pulses, the default value is 10, and the adjustment range is 1 to 120 with 1 steps. Confirm or set when installing.

DISPLAY POSITION: Set the position of the rotor dial is on the right or left, the default is on the right.

6.1.4 EGT SETUP

EGT SETUP	
★PROBE :	K-TYPE
CALIBRATION FACTOR :	+0
EGT CHANNEL :	2
TEMPERATURE UNIT :	°C
DISPLAY MAX :	1000 °C
DISPLAY MIN :	0 °C
HIGH ALARM :	880 °C
HIGH CAUTION :	700 °C
LOW CAUTION :	0 °C
LOW ALARM :	0 °C
DIFFERENCE ALARM :	25 °C
ALARM :	OFF

Fig. 34 EGT setup

In the submenu, move the ★ pointer to EGT SETUP, press ENTER to enter the EGT set up menu.

PROBE: K or J type thermocouple, the default is K-type.

EGT CHANNEL : Number of EGT channels, range: 1-4, the default value is automatically adjusted according to the parameter data interface..

DIFFERENCE ALARM: The alarm value of the temperature difference between two cylinders, an alarm will be given when the difference between the maximum and minimum temperature in the channels exceeds this value.

6.1.5 CHT SETUP

In the submenu, move the ★ pointer to CHT SETUP, press ENTER to enter the CHT set up menu.

```

          CHT SETUP
★LABLE :          CHT
  PROBE :          J-TYPE
CALIBRATION FACTOR : +0
  CHT CHANNEL :    2
TEMPERATURE UNIT : °C
  DISPLAY MAX :    150 °C
  DISPLAY MIN :    0 °C
  HIGH ALARM :     135 °C
  HIGH CAUTION :   100 °C
  LOW CAUTION :    0 °C
  LOW ALARM :      0 °C
  DIFFERENCE ALARM : 10 °C

```

Fig. 35 CHT setup

LABLE: CHT or Coolant.

PROBE: ROTAX-NTC, PT100, K or J-type thermocouple, CH-NTC(**Note:** CFI/Westach-NTC) can be selected.

Note: The signal shall be connected to CHT1R and CHT2R ports of parameter processor when data interface is set as parameter processor and PT100, ROTAX-NTC and CH-NTC are selected as sensor type.

Refer to *EGT SETUP* for the rest.

6.1.6 FUEL SETUP

In the submenu, move the ★ pointer to FUEL SETUP, press ENTER to enter the FUEL set up menu.

```

          FUEL SETUP
★FUEL PRESSURE DISPLAY : ON
  PRESSURE UNIT :        BAR
  PRESSURE SENSOR RANGE 30 PSI
  FUEL FLOW DISPLAY :    ON
  FUEL UNIT :            LITER
  FUEL FLOW K FACTOR :   7000 P/L
  FUEL LEVEL SIZE :     235 L
  FUEL LEVEL L :        ON
  FULE LEVEL R :        OFF
  ZERO-SCALE VOLTAGE :  0.04 V
  FULL-SCALE VOLTAGE :  5.00 V
  FILTER :              0
  ALARM :               OFF

```

Fig. 36 Fuel setup

Note: The fuel pressure sensor must be a voltage type sensor with an output value of 0.5-4.5v.

PRESSURE UNIT: PSI or BAR.

PRESSURE SENSOR RANGE: Range: 1-100PSI or 0.1-3.0bar.

FUEL UNIT: GAL(GAL/H) or LITER(LITER/H).

FUEL FLOW K FACTOR: The number of revolutions or pulses of the fuel pump per unit flow.

FUEL LEVEL SIZE: Total tank volume(size).

FUEL LEVEL L: ON/OFF, ON by default.

FULE LEVEL R: OFF/ON, OFF by default.

ZERO-SCALE VOLTAGE: The output voltage of the sensor when the tank is empty.

FULL-SCALE VOLTAGE: The output voltage of the sensor when the tank is full.

FILTER: Average the fule level in a period of time to reduce the fluctuation of the displayed value. Range: 1-120 seconds, default value: 0, not average.

6.1.7 MAINFOLD PRESSURE SETUP

In the submenu, move the ★ pointer to MAINFOLD PRESSURE, press ENTER to enter the MAINFOLD PRESSURE set up menu.

MAINFOLD PRESSURE	
★DISPLAY :	ON
PRESSURE UNIT :	hPa
DISPLAY MAX :	1400 hPa
HIGH ALARM :	1150 hPa
HIGH CAUTION :	1100 hPa
LOW CAUTION :	200 hPa
DISPLAY MIN :	0 hPa
ALARM :	OFF

Fig. 37 Mainfold pressure setup

PRESSURE UNIT: hPa or inHg.

DISPLAY MAX: The default value is 1400hPa or 41.3inHg, the adjustment range is 0 to 10000 with 50 steps.

DISPLAY MIN: The default value is 0, the adjustment range is 0 to 200 hPa with 50 steps.

6.1.8 OIL PRESSURE SETUP

In the submenu, move the ★ pointer to OIL PRESSURE SETUP, press ENTER to enter the OIL PRESSURE set up menu.

OIL PRESSURE SETUP	
★DISPLAY :	ON
PRESSURE UNIT :	BAR
SENSOR :	OIL-VP
SENSOR MAX:	10.0 BAR
SENSOR MIN:	0.0 BAR
DISPLAY MAX :	10.0 BAR
HIGH ALARM :	7.0 BAR
HIGH CAUTION :	5.0 BAR
LOW CAUTION :	2.0 BAR
LOW ALARM :	0.8 BAR
DISPLAY MIN :	0.0 BAR
ALARM :	OFF

Fig. 38 Oil pressure setup

PRESSURE UNIT: PSI or BAR.

SENSOR: OIL-VP(voltage type sensor) or OIL-IP Absolute(current type absolute sensor) or OIL-IP Gauge(current type gauge sensor).

Note: When the data interface is set as the parameter processor, if the voltage sensor is used, the signal shall be connected to the OIL-VP port, if the current sensor is used, the signal shall be connected to the OIL-IP port.

SENSOR MAX: Corresponding pressure value when the pressure sensor outputs 20mA (current type) / 4.5V (voltage type), see the label or instructions of the sensor.

SENSOR MIN: Corresponding pressure value when the pressure sensor outputs 4mA (current type) / 0.5V (voltage

type), see the label or instructions of the sensor.

6.1.9 ANALOG SETUP

In the submenu, move the ★pointer to ANALOG SETUP, press ENTER to enter the ANALOG set up menu.

ANALOG SETUP	
★LABLE :	OILT
SENSOR :	ROTAX NTC
CALIBRATION FACTOR :	+0
FILTER :	OFF
TEMPERATURE UNIT :	°C
DISPLAY MAX :	150 °C
HIGH ALARM :	130 °C
HIGH CAUTION :	110 °C
LOW CAUTION :	90 °C
LOW ALARM :	50 °C
DISPLAY MIN :	50 °C
ALARM :	OFF

Fig. 39 Analog(temperature sensor) setup

LABLE: Measurement items, OT(OILT) and WT(WAT) can be selected.

SENSOR: PT100 or ROTAX-NTC or CH-NTC(CFI/Westach-NTC);

FILTER: The default is OFF and can be turned on when the temperature display value fluctuates.

6.1.10 VOLT SETUP

In the submenu, move the ★pointer to VOLT SETUP, press ENTER to enter the VOLT set up menu.

VOLT SETUP	
★DISPLAY :	ON
DISPLAY MAX :	16.0 V
HIGH ALARM :	14.0 V
HIGH CAUTION :	13.0 V
LOW CAUTION :	11.0 V
LOW ALARM :	10.0 V
DISPLAY MIN :	8.0 V
ALARM :	OFF

Fig. 40 Volt setup

6.1.11 AMPS SETUP

In the submenu, move the ★pointer to AMPS SETUP, press ENTER to enter the AMPS set up menu.

AMPS SETUP	
★DISPLAY :	ON
DISPLAY MAX :	60 A
HIGH ALARM :	50 A
HIGH CAUTION :	40 A
LOW CAUTION :	-40 A
LOW ALARM :	-50 A
DISPLAY MIN :	-60 A
SPAN CALIBRATION :	±60 A
CALIBRATION FACTOR :	+0 A
ZERO CORRECTION:	
ALARM :	OFF

Fig. 41 Amps setup

SPAN CALIBRATION: The rated current value of the shunt with a voltage drop of 50mV, the default is 60A. The system is limited to uses of shunt with a voltage drop of 50mV. The wires connected to AMP+ and AMP- must use **twisted pair shielded wire**, and the shield layer is connected to pin 15 of J1 or the chassis ground.

ZERO CORRECTION: If the current data comes from the parameter processor(Can use unshielded twisted pair), the

zero correction must be carried out. Correction method: connect the close power supply end of the shunt to AMP+ and AMP- of the parameter processor at the same time, move the ★ pointer to ZERO CORRECTION, press ENTER to enter, press UP to switch to OK, press OK to confirm. Connect the AMP+ and AMP- of the parameter processor to both ends of the shunt normally, if the indicated current value is different from the actual current value, it can be adjusted through **CALIBRATION FACTOR**.

6.1.12 OAT/CarbT SETUP

In the submenu, move the ★ pointer to OAT/CarbT SETUP, press ENTER to enter the OAT/CarbT set up menu.

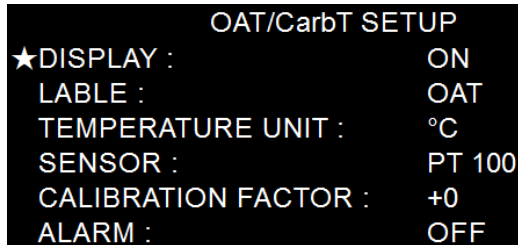

Fig. 42 OAT/CarbT setup

LABEL: OAT or CarbT.

SENSOR: PT100 or ROTAX-NTC or CFI-NTC(CFI/Westach-NTC), the default is PT100.

6.1.13 RT SETUP

In the submenu, move the ★ pointer to RT SETUP, press ENTER to enter the RT set up menu.

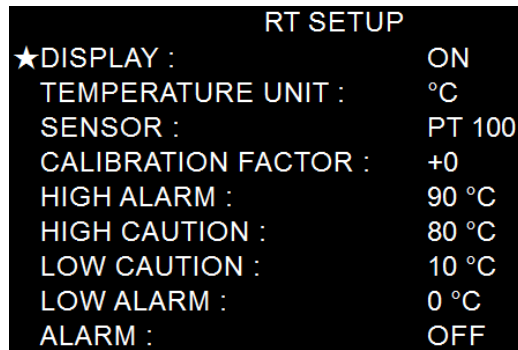

Fig. 43 RT setup

SENSOR: PT100 or ROTAX-NTC or CFI-NTC(CFI/Westach-NTC), the default is PT100.

6.2 TRIM & FLAP & THROTTLE SETUP

In the main menu, move the ★ pointer to TRIM & FLAP & THROTTLE, press ENTER to enter the TRIM & FLAP & THROTTLE set up submenu.

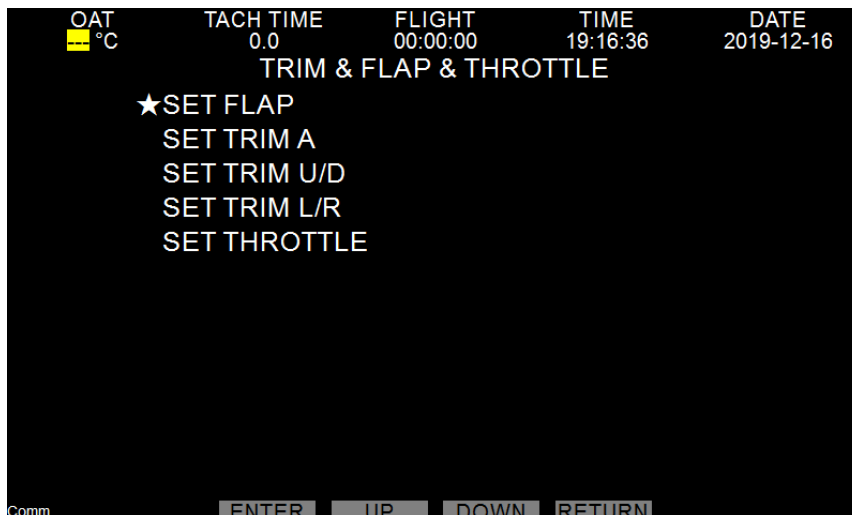

Fig. 45 Trim & flap & throttle setup

6.2.1 TRIM & FLAP SETUP

In the submenu, move respectively the ★ pointer to SET FLAP and each SET TRIM #, press ENTER to enter the relevant set up menu. The default minimum position corresponds to the output zero (0%) of the displacement sensor, and the default maximum position corresponds to the output high (100%) of the displacement sensor.

MIN POS. SET: Select SET # MIN POS. in the menu, turn the wing and the trim to the minimum position, select CURRENT and press OK to confirm. The integrated display confirms that the current output value of the potentiometer corresponds to the minimum position of the wing/rudder. Select RESET and confirm to restore the default value of 0%.

MAX POS. SET: Select SET # MAX POS. in the menu, turn the wing and the trim to the maximum position, select CURRENT and press OK to confirm. The integrated display confirms that the current output value of the potentiometer corresponds to the maximum position of the wing/rudder. Select RESET and confirm to restore the default value of 100%.

SET FLAP ANGLE MAX: The default maximum flap angle is 20°, and the adjustment range is 1 to 50°.

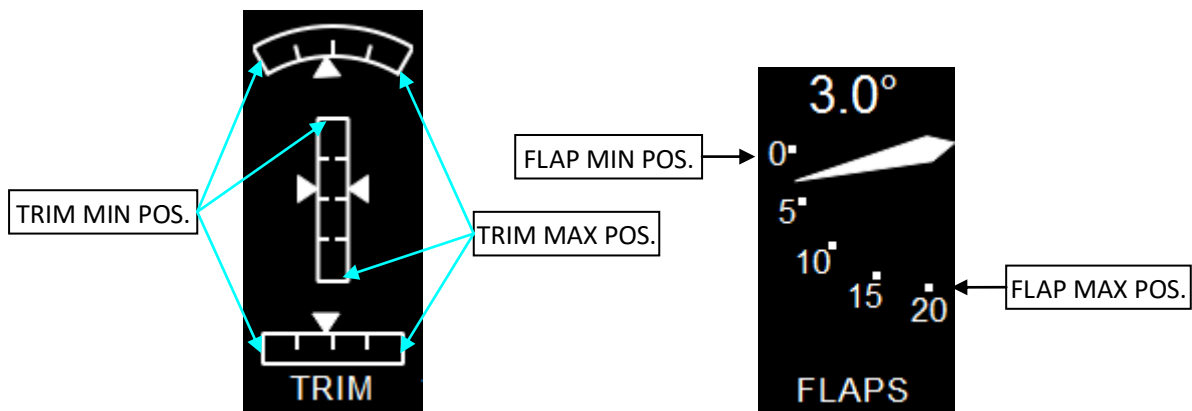

Fig. 45 Indication of flap and trim position

6.2.2 SET THROTTLE

In the submenu, move the ★ pointer to SET THROTTLE, press ENTER to enter the THROTTLE set up menu.

```

SET THROTTLE
★DISPLAY :      ON
DISPLAY MIN :   0.0 V
DISPLAY MAX :   5.0 V
  
```

Fig. 46 Throttle setup

DISPLAY MIN: Push or drive the throttle stick to the minimum position, measure the output voltage of the driver or potentiometer, select **DISPLAY MIN** in the menu, set the minimum value to this voltage value and press OK to confirm. The default is 0V.

DISPLAY MAX: Push or drive the throttle stick to the maximum position, measure the output voltage of the driver or potentiometer, select **DISPLAY MAX** in the menu, set the maximum value to this voltage value and press OK to confirm. The default is 5V.

6.3 PFD SETUP

In the main menu, move the ★ pointer to PFD SETUP, press ENTER to enter the PFD set up submenu.

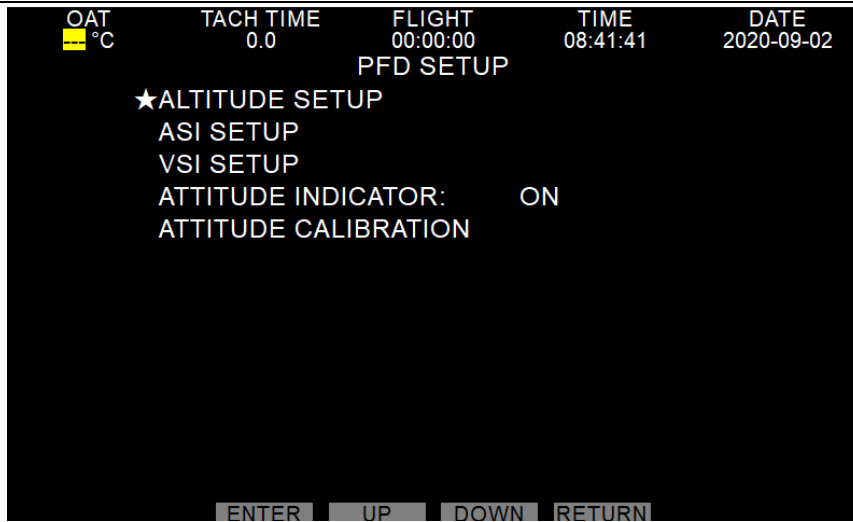

Fig. 47 PFD setup

ATTITUDE INDICATOR: Select ATTITUDE INDICATOR and turn on / off the attitude indicator module.

6.3.1 ALTITUDE SETUP

In the submenu, move the ★pointer to ALTITUDE SETUP, press ENTER to enter the ALTITUDE set up menu.

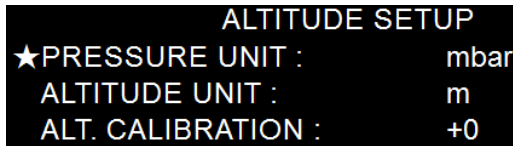

Fig. 48 Altitude setup

PRESSURE UNIT: The reference barometric unit, can be mbar or inHg.

ALTITUDE UNIT: m or ft.

ALTI. CALIBRATION: Altimeter calibration. This value is the AD conversion correction value of the altimeter. If this value increases, the height becomes smaller, otherwise, the height becomes larger. At sea level, if the variation is about 2m (6.56ft), it will be about 5m (16.4ft) at 10000m.

Note: Do not modify this value at will. Please calibrate it with higher precision altimeter when modifying, and the field reference barometric setting is the same.

6.3.2 ASI SETUP

In the submenu, move the ★pointer to ASI SETUP, press ENTER to enter the ASI set up menu.

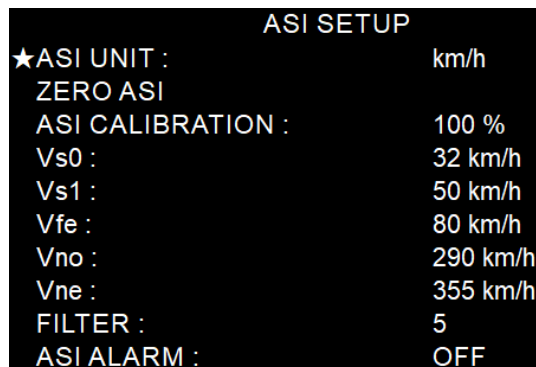

Fig. 49 ASI setup

ASI UNIT: km/h or mph or knots.

ZERO ASI: Set Airspeed to zero. The setting is to be carried out 1 minute after the power on, and at the same time, the pressures at the ‘P’ and ‘S’ openings must be equal. It is recommended to connect the two openings with a tube.

ASI CALIBRATION: Airspeed calibration. When there is an error in the aircraft airspeed system, an airspeed

correction coefficient can be set, and the displayed value = measured value × correction coefficient.

V#*: The airspeed range of each segment, that is, the start and stop speed of some segment of airspeed marking color band.

6.3.3 VSI SETUP

In the submenu, move the ★ pointer to VSI SETUP, press ENTER to enter the VSI set up menu.

```

VSI SETUP
★VSI UNIT :          m/s
DISPLAY MAX :        10 m/s
VSI CALIBRATION :    100 %
FILTER :             ON
  
```

Fig. 50 VSI setup

VSI UNIT: m/s or ft/min.

DISPLAY MAX: The default is 2000 ft/min and 10 m/s; The range can be 4000, 6000, 8000ft/min and 20, 30, 40 m/s.

VSI CALIBRATION: Vertical speed calibration. When there is an error in the vertical speed (calibrated by the standard table), a vertical speed correction coefficient can be set, and the display value = measurement value × calibration coefficient.

FILTER: The default is OFF and can be turned on when the air flow is unstable and the vertical speed fluctuates.

6.3.4 ATTITUDE CALIBRATION

In the submenu, move the ★ pointer to ATTITUDE CALIBRATION, press ENTER to enter the ATTITUDE calibration menu. Enter each item of the menu, you can calibration, zero and reset the installation error and indication error of the attitude indicator module.

```

ATTITUDE CALIBRATION
★PITCH CALIBRATION  +0.0 °
ROLL CALIBRATION    +0.0 °
HEADING CALIBRATION +0.0 °
SLIP/SKID CALIBRATION +0.0 °
ZERO PITCH
ZERO ROLL
ZERO SLIP/SKID
RESET ALL
Curent Pitch: +0.0°
  
```

Fig. 51 Attitude calibration setup

6.4 TIME & DATA

In the main menu, move the ★ pointer to TIME & DATA SETUP, press ENTER to enter the TIME & DATA set up submenu. Enter each item of this menu, and you can modify and set the year, month, day, hour, minute and second.

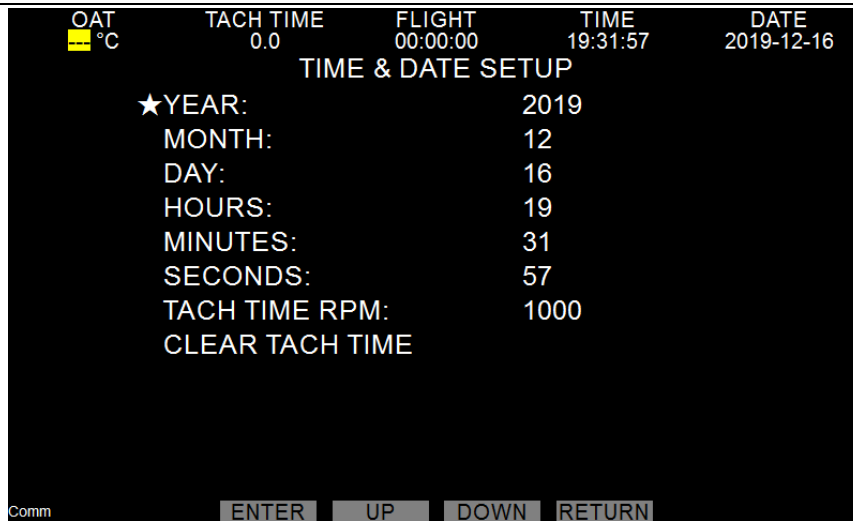

Fig. 52 Time & data setup

TACH TIME RPM: Controls when to start or stop the flight timer. The flight timer starts when the engine RPM reaches the TACH TIME RPM for 10 seconds. The flight timer stops and keep the data when the engine RPM is lower than the TACH TIME RPM for 10 seconds. The default flight timing speed is 1000rpm.

CLEAR TACH TIME: The accumulation of flight time of each segment of the aircraft. Please clean it carefully.

6.5 SYSTEM SETUP

In the main menu, move the ★ pointer to SYSTEM SETUP, press ENTER to enter the SYSTEM set up submenu.

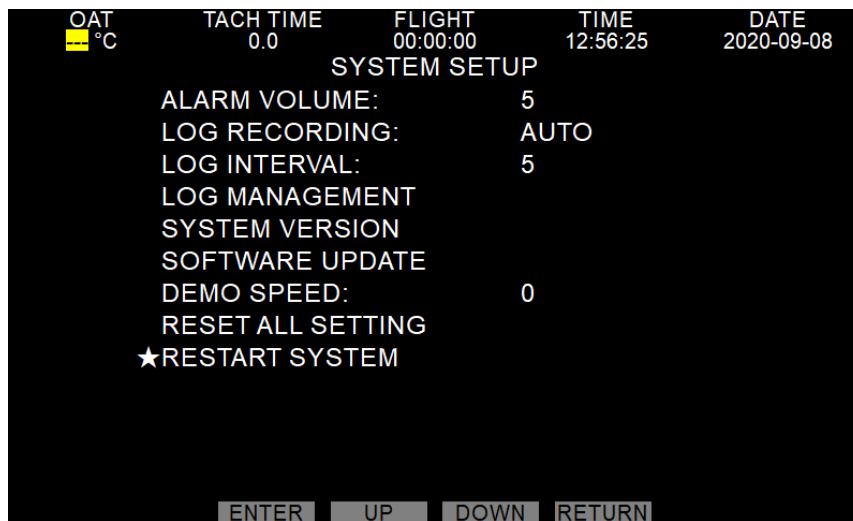

Fig. 53 System setup

ALARM VOLUME: The alarm volume is divided into 10 levels, and the default is level 5.

LOG RECORDING: The mode of recording flight data, AUTO by default, can also be set to ON and OFF;

AUTO: The integrated display automatically records the flight data when the aircraft starts to count the flight time;

ON: The flight data will be recorded when the power is on;

OFF: Flight data is not recorded.

LOG INTERVAL: The unit is seconds. The default is 5 seconds.

LOG MANAGEMENT: See 6.5.1;

SYSTEM VERSION: In the submenu, move the ★ pointer to SYSTEM VERSION, the software version of the integrated display and the software version of the parameter processor will be displayed at the bottom of the page.

SOFTWARE UPDATE: See 6.5.2;

DEMO SPEED: The default value is 0, which is in normal working condition. If it is not 0, demonstration mode is started, the larger the value is, the greater the change of demonstration data.

RESET ALL SETTING: Reset all settings to the factory default settings.

RESART SYSTEM: Restart the integrated display.

6.5.1 LOG MANAGEMENT

In the submenu, move the ★ pointer to LOG MANAGEMENT, press ENTER to enter the LOG management menu.

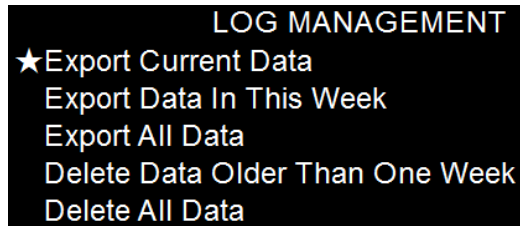

Fig. 54 Log management

Export Current Date: Export current (today 's) log data.

Export Data In This Week: Export log data from this week (the last 7 days).

Export All Data: Export all log data.

Delete Data Older Than One Week: Delete log data from this week (the last 7 days). **Please operate carefully!**

Delete All Data: Delete all log data. **Please operate carefully!**

The steps to export log data are as follows:

- 1) Prepare a USB drive (FAT32 format) and insert it into the USB port of the integrated display;
- 2) Select the data to be exported, move the ★ pointer to the task to be exported, press ENTER to confirm, pull out the USB drive after the task is completed, and view the log data on the computer.

6.5.2 SOFTWARE UPDATE

The software upgrade steps are as follows:

- 1) Copy the update file to a USB drive (FAT32 format);
- 2) Insert the USB drive to this integrated display;
- 3) In the submenu, move the ★ pointer to SOFTWARE UPDATE, press ENTER to enter the SOFTWARE update menu.
- 4) Move the ★ pointer to the file name to be updated (**[**] .upk), press the lower right CRC32 button to obtain the check code, which will be displayed at the bottom of the screen, and check whether the check code is the same as the [**] in the file name. If it is the same, the next step can be carried out. Otherwise, the file needs to be copied again if it is damaged.
- 5) Press ENTER to confirm the update, press OK to start the update, and the software will automatically restart after the update is completed (about 20 seconds).

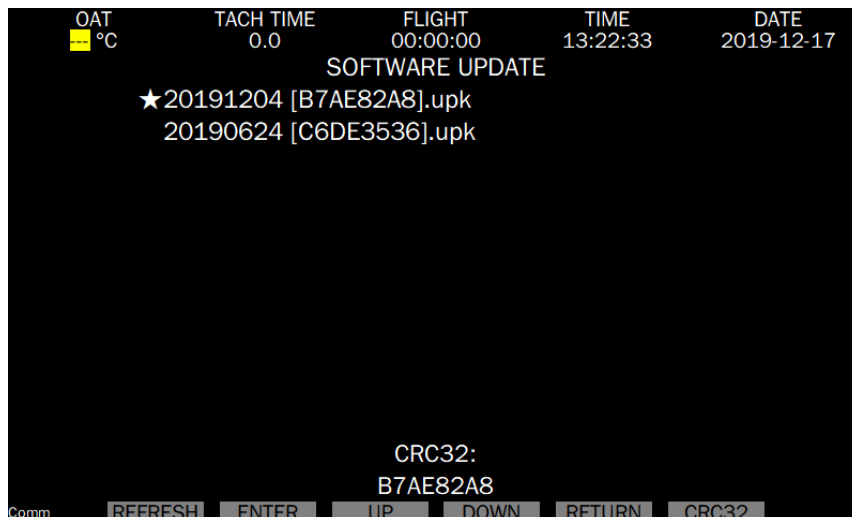

Fig. 55 Software update

6.5.3 RESART SYSTEM

In the submenu, move the ★ pointer to RESTART SYSTEM, press ENTER button, and an important prompt as shown in the figure will appear on the interface.

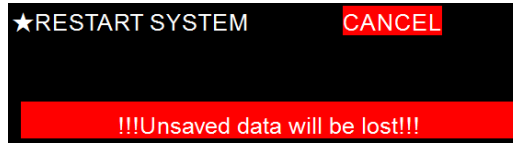

Fig. 56 Restart system

7 Flight data record

7.1 Related setting

Enter in “menu”>“SYSTEM SETUP”>“LOG RECORDING:” to set the record mode: AUTO (*automatically*, record data after flight timing); ON: always record; OFF: don't record.

Enter in “menu”>“SYSTEM SETUP”>“LOG INTERVAL:” to set the record interval , units: second.

Note: CF3000A will check the remaining storage space when it starts. Delete the old record when space is less than 20 MB until remaining space is larger than 20 MB.

7.2 Log format

The flight log, with filename containing today's date, is stored in the file with suffix “.dat”. For example: the name file on September 16, 2019 is: “20190916.dat”.

Logs from the same day are stored in the same file. Log type is Unicode encoding. Record one piece of data at a time according to the log interval. Format is as follows:

TIME	FuelFlow	FuelLevel1	FuelLevel2	FuelP	RPM	Slip/Skid
13:35:48	12.3	22.3	23.4	1234	1234	12
13:35:53	13.3	23.3	24.4	1235	1235	13
13:35:58	14.3	24.3	25.4	1236	1236	14

The meaning of labels and data is as follows:

Explain	Label	Unit	Example
Current time	TIME	HH:MM:SS	12:34:56
Fuel flow	FuelFlow	L/h	12.3(12.3L/h)
Fuel level 1	FuelLevel1	L	22.4(22.4L)
Fuel level 2	FuelLevel2	L	23.4(23.4L)
Fuel pressure	FuelP	hPa	1234(1234hPa)
Engine RPM	RPM	r/min	1234(1234r/min)
Rotor RPM	ROT	r/min	123(123r/min)
Manifold pressure	MAP	hPa	1234(1234hPa)
Oil pressure	OilP	hPa	1234(1234hPa)
Oil/water temperature	OT/WAT	°C	123(123°C)
Voltage	VOT	V	12.3(12.3V)
Current	AMP	A	12(12A) or -12(-12A)
Rotor temperature	RT	°C	123(123°C)
Outside air temperature	OAT	°C	123(123°C)
Exhaust gas temperature 1	EGT1	°C	123(123°C)
Exhaust gas temperature 2	EGT2	°C	123(123°C)

CF3000A User Guide

Exhaust gas temperature3	EGT3	°C	123(123°C)
Exhaust gas temperature4	EGT4	°C	123(123°C)
Cylinder-head/ Coolant temperature 1	CHT1	°C	123(123°C)
Cylinder-head/ Coolant temperature 2	CHT2	°C	123(123°C)
Cylinder-head/ Coolant temperature 3	CHT3	°C	123(123°C)
Cylinder-head/ Coolant temperature 4	CHT4	°C	123(123°C)
Flight time	FlightTime	HH:MM:SS	12:34:56
Tach time	TotalHour	hour	123.4(123.4h)
Indicated airspeed	AS	km/h	123(km/h)
True airspeed	TAS	km/h	123(km/h)
Altitude	ALT	m	1234(1234m)
Vertical speed	VS	m/s	+12.34(12.34m/s) or -12.34(-12.34m)
Throttle position	Throttle	%	12(12%)
Flap position	Flap	°	12(12°)
Trim A position	TRIM_A	%	12(12%)
Trim U/D position	TRIM_U/D	%	12(12%)
Trim L/R position	TRIM_L/R	%	12(12%)
Pitch	Pitch	°	12.3(12.3°)
Roll	Roll	°	12.3(12.3°)
Heading	Heading	°	12.3(12.3°)
Slip/Skid	Slip/Skid	°	12.3(12.3°)

The recorded parameter unit is fixed and immutable, and does not adjust with the adjustment of the displayed parameter unit.

If the corresponding data of the parameter is invalid or the communication is abnormal, the corresponding parameter value will be displayed as "---".

The record file can be opened with Microsoft Excel and other software, and the effect is as follows:

	A	B	C	D	E	F	G	H	I	J	K	L	M	N	O	P	Q	R	S	T	U	V	W	
1	TIME	FuelFlow	FuelLevel1	FuelLevel2	FuelP	RPM	ROT	MAP	OilP	OT/WAT	VOT	AMP	RT	EGT1	EGT2	EGT3	EGT4	CHT1	CHT2	CHT3	CHT4	FlightTime	TotalHour	
2	13:35:48	12.3	22.3	23.4	1234	1234	123	1234	1234	123	12.3	12	123	123	123	123	123	123	123	123	123	123	123	123
3	13:35:53	13.3	23.3	24.4	1235	1235	124	1235	1235	124	13.3	13	124	124	124	124	124	124	124	124	124	124	124	124
4	13:35:58	14.3	24.3	25.4	1236	1236	125	1236	1236	125	14.3	14	125	125	125	125	125	125	125	125	125	125	125	125
5	13:36:03	15.3	25.3	26.4	1237	1237	126	1237	1237	126	15.3	15	126	126	126	126	126	126	126	126	126	126	126	126
6	13:36:08	16.3	26.3	27.4	1238	1238	127	1238	1238	127	16.3	16	127	127	127	127	127	127	127	127	127	127	127	127
7	13:36:13	17.3	27.3	28.4	1239	1239	128	1239	1239	128	17.3	17	128	128	128	128	128	128	128	128	128	128	128	128
8	13:36:18	18.3	28.3	29.4	1240	1240	129	1240	1240	129	18.3	18	129	129	129	129	129	129	129	129	129	129	129	129
9	13:36:23	19.3	29.3	30.4	1241	1241	130	1241	1241	130	19.3	19	130	130	130	130	130	130	130	130	130	130	130	130
10	13:36:28	20.3	30.3	31.4	1242	1242	131	1242	1242	131	20.3	20	131	131	131	131	131	131	131	131	131	131	131	131
11	13:36:33	21.3	31.3	32.4	1243	1243	132	1243	1243	132	21.3	21	132	132	132	132	132	132	132	132	132	132	132	132
12	13:36:38	22.3	32.3	33.4	1244	1244	133	1244	1244	133	22.3	22	133	133	133	133	133	133	133	133	133	133	133	133
13	13:36:43	23.3	33.3	34.4	1245	1245	134	1245	1245	134	23.3	23	134	134	134	134	134	134	134	134	134	134	134	134
14	13:36:48	24.3	34.3	35.4	1246	1246	135	1246	1246	135	24.3	24	135	135	135	135	135	135	135	135	135	135	135	135

8 Troubleshooting

Problem Description	Possible Cause	Solution
Unable to power on	On-board power supply failure, and standby battery are not connected or have been fully discharged. The fuse in the integrated display is blown	Check the on-board power supply and connection plug. Return to the factory to replace the fuse
The airspeed does not read 0 when the actual airspeed is 0	There is wind interference at the nozzle of airspeed pipe. The airspeed indicator needs zero calibration	Eliminate the interference of wind. Go to airspeed settings menu > zero calibration, see 6.3.2 ASI SETUP
Incorrect pitch, roll and slip angle	Uncalibrated altitude or need to be recalibrated	After installation, the altitude calibration shall be carried out when the aircraft is in a horizontal state. See 6.3.4 ALTITUDE CALIBRATION , and refer to Altitude Heading Reference System (AHRS) Instructions
Heading angle error	Maybe AHRS doesn't point to the North in installation or AHRS is interfered by hard magnetic objects	Refer to Altitude Heading Reference System (AHRS) Instructions

9 Screen Care

Use a dry, clean, soft cloth to clean the screen. Do not use soap, chemicals, or abrasives to avoid damaging the screen. You may also use commercially available wipes that are designed specifically for LCD screen cleaning. Never use water or solvents when attempting to clean the display.



Avoid excessive pressure to the display to prevent damage to the LCD (Liquid Crystal Display). Take care to prevent impacts to the screen to prevent cracking the display.

Appendix 1: CF3000A display parameter list

Parameter Name	CAN communication (912is/915is)	Single Display	adding Parameter Processor	Can be OFF?
Altitude		1		
Airspeed		1		
Vertical speed		1		
Horizon(pitch, roll)		Displayed when adding AHRS		
Slip		Displayed when adding AHRS		
Heading		Displayed when adding AHRS		
Throttle	1	1	1	Y
Flap	1	1	1	Y
TRIM	3		3	Y
MAP	1		1	Y
Engine TACH	1	1 ^{*3}	1 ^{*3}	
Rotor TACH	1	1	1	Y
Rotor TEMP	(R signal)1	1(R signal)	1	Y
EGT(Thermocouple)	4	1	2+2 ^{*1}	
CHT(Thermocouple)			2+2 ^{*1}	
OIL/WATER TEMP	1	1(R signal)	1	
OIL PRESS	1	1 ^{*2}	1(V or I signal)	Y
FULL PRESS	1 ^{*2}	1 ^{*2}	1 ^{*2}	Y
AMP	1	1	1	Y
VOLT	1	1	1	Y
FUEL%	2	2	2	
FUEL FLOW	1		1	Y
CHT/Coolant T(R signal)	1	1	2	
OAT/Carb T	1	1	1	Y
SPARE(V signal)	1 ^{*4}	1 ^{*4}	1 ^{*4}	
SPARE(R signal)	3 ^{*4}	1 ^{*4}	1 ^{*4}	
Audio Output		1		
CLOCK		1		
FLT TIME		1		

*1. There are two special interfaces for EGT and CHT, sharing two general interfaces.

*2. For voltage signal only, the output value of the sensor is 0.5-4.5v.

*3. Pulse  signal, square wave  signal and signal from magneto are connected to different terminals of the display or the parameter processor, and the amplitude of input signal shall not exceed 36V generally.

*4. If you need to enable the spare voltage and resistance input pins, you must cooperate with the customized program.

Appendix 2: Mounting hole cut out